

A modern living room featuring a dark wood laminate floor. In the foreground, a yellow armchair and ottoman are positioned near a large window. A tall black floor lamp stands to the left. In the background, a white bookshelf is filled with books, and a desk with a red chair is visible on the right. The room is bright and airy, with natural light coming from the window.

Whiteriver

wood for living

LAMINATE FLOORING

What is Laminate Wood Flooring?



- A** Clear protective layer
- B** Decorative layer
- C** High-density fibreboard core

Laminate wood flooring consists of a number of stable layers which ensure the extraordinary durability and unique quality of our flooring.

- A.** The top surface of the floor consists of a specially resistant protective overlay film. This is fused with an attractive wood effect decorative film into a practically abrasion proof, hard wearing surface.
- B.** Extremely dense HDF fibreboard forms the supportive core.
- C.** An anti-damp film ensures and preserves the high structural stability.

The look and feel of high-quality laminate floors make them virtually indistinguishable from solid wood. Unlike solid wood floors, they consist of a HDF wood core layer covered with a decorative layer. Laminate flooring comes in various widths, lengths and thickness's to suit all applications. Long plank formats with surrounding V-joint and nature-identical embossing are now especially desirable as they replicate genuine country house style plank floors more accurately than ever before.

Surface treatment that is embossed in register (ER), in other words, the surface of the floor follows the same grain as natural wood with real indentations and graining across the plank as opposed to a totally smooth finish for an authentic look.

Laminate flooring is also robust, fade resistant, easy to clean, and has low emissions. A big advantage over real wood flooring, apart from being kinder on your wallet, is that you can easily install laminate yourself. A tongue-and-groove click-together system makes it incredibly simple to install attractive floors yourself.

Laminate flooring is at home everywhere: in living rooms, kitchens and bedrooms as well as in commercial spaces such as offices, hotels and restaurants.

There are a wide range of different decors to choose from to help you achieve your personal decorating style. Whether you prefer classic oak, nature-identical wood styles or contemporary adaptations, there are virtually no limits to your individual creativity with this versatile floor covering. These floors are simple to install and hard-wearing.

Laminate flooring consists of approximately 90% wood, a natural material, making it an eco-friendly option delivering both health and environmental benefits.

Our range is complemented with a wide range of accessories including sound insulating underlay, skirting boards and trims for that finishing touch.

Laminate flooring meets all expectations with regard to modern day living. They are easy to clean by vacuuming or wiping with a slightly damp mop and due to the protective top layer are highly stain resistant. The smooth, unbroken surfaces prevent allergy-provoking microorganisms from accumulating resulting in a clean, hygienically flawless floor – thus making laminate especially suited for people with allergies.

We hope you enjoy browsing through our collections where you will find the best floor for your project. Our full range of flooring including engineered real wood, solid flooring as well as composite decking can all be found on our website www.wrg.ie while our range of Seadec internal doors can be found at www.seadec.ie



LONG PLANK

10MM MAMMUT PLUS LONG PLANK 4V	09
12MM MAMMUT LONG PLANK 4V	15
8MM TRITTY 100 GRAN VIA 4V	23

STANDARD PLANK

12MM ROBUSTO 4V	31
12MM EVOLUTION 4V	41
10MM METRO 4V	45
10MM METRO HIGH SHINE	51
8MM HERRINGBONE 4V	53
8MM EXQUISIT PLUS WIDE 244MM 4V	59
8MM DYNAMIC 4V	65
8MM EXCEL 4V	73
6MM & 7MM	77

HARO DISANO AQUA

9.3MM DISANO AQUA CLASSIC 4V	85
------------------------------	-----------

ACCESSORIES

UNDERLAYS	91
WHITE PRIMED SKIRTING & ARCHITRAVE	93
PREFINISHED SKIRTING	94
SCOTIA	95
STAIR NOSING	96
FLOORING PROFILES	98
MEASUREMENT GUIDE	100

INSTALLATION & AFTERCARE

INSTALLATION MADE EASY	101
GENERAL GUIDELINES	102
INSTALLATION INSTRUCTIONS	103
UNDERFLOOR HEATING	104
LAMINATE CARE & MAINTENANCE	105
ARCHITECTS & DESIGNER	106

EXPLORE OUR EXTENDED PRODUCT CATEGORIES ONLINE @ WWW.WRG.IE



LAMINATE & ENGINEERED FLOORING, COMPOSITE DECKING, ACCESSORIES, LACQUERS AND SEADECK DOORS

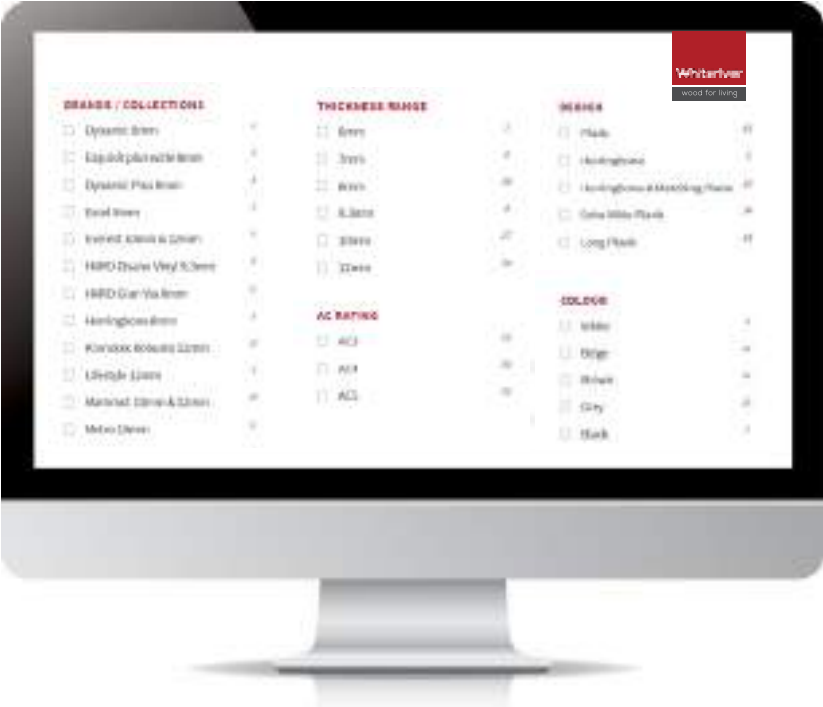

SEARCH BY DESIGN, BRAND, COLOUR AND BOARD SIZE

EXPLORE OUR EXTENDED PRODUCT CATEGORIES ONLINE @ WWW.WRG.IE

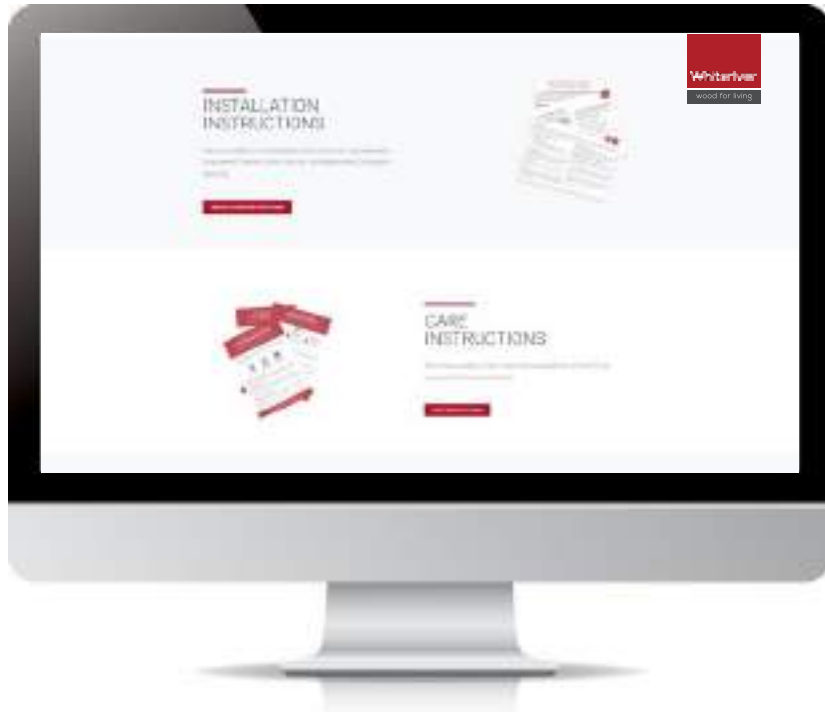

**VIEW & DOWNLOAD INSTALLATION INSTRUCTIONS,
CARE & MAINTENANCE GUIDES AND PRODUCT DATA SHEETS**

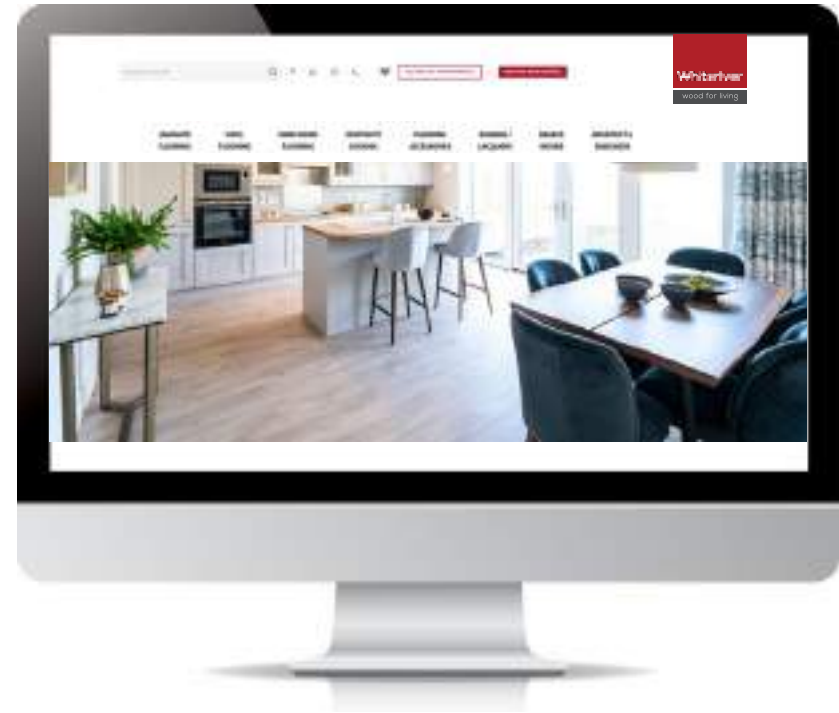

LATEST PRODUCT DEVELOPMENT AND RECENT PROJECTS

characteristics



Product Thickness

Indicates overall thickness of board.



4V Groove

V groove on all edges of board for natural plank appearance.



5G Click System

Premium 5G click system makes the floor even easier to install.



Underfloor Heating

Suitable for use with underfloor heating.



Drop Lock

Simple push down secure click system.



Long Plank

These panels are especially long.



Angle Angle Installation

Glue-less click installation.



Wide Plank

These panels are especially wide



Moisture Guard

Improved moisture guard core board which gives enhanced anti swelling performance over standard laminates.



AquaTec

Double moisture protection exclusive to our HARO Gran Via Floors.



Blue Angel Certified

*All our laminate floors in this brochure are Blue Angel certified for low emissions, sustainability & environment.

**Excludes 10 mm Aged Ash, 12 mm Carlingford Oak, 12 mm Kinsale Walnut & 12 mm American walnut*



Floor Score

FloorScore® is the most recognized indoor air quality (IAQ) certification standard for hard surface flooring materials, adhesives, and underlayments. Developed by SCS with the Resilient Floor Covering Institute (RFCI), a leading industry trade association of flooring manufacturers and suppliers.

WEAR RATING

All laminate floors resistance to wear is given as an abrasion class.



Suitable for high traffic domestic everyday use.



Suitable for light commercial and domestic everyday use.



Suitable for medium traffic commercial & domestic everyday use.



Suitable for high traffic commercial & everyday use.

WARRANTY

All our floors come with a 6, 20, 25 or 30 year residential warranty.

For full Warranty details visit www.wrg.ie



surface finishes

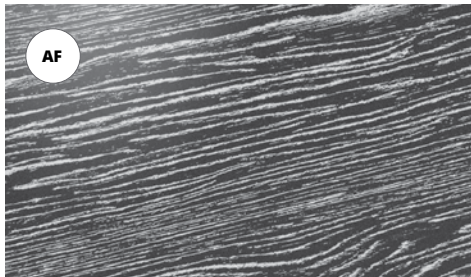

AF AUTHENTIC FLOOR
Natural and vivid wood texture



ER REGISTERED EMBOSS
Genuine wood appearance due to consistency between pattern and embossing

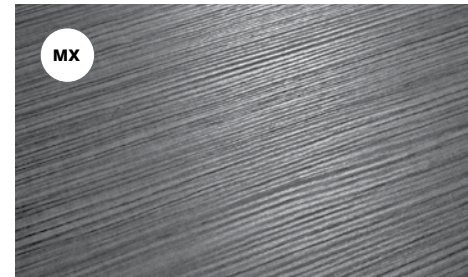

MX MATRIX
Deep structure embossing with typical wood matt/gloss contrast



PR WOOD PORE
Typical wood structure

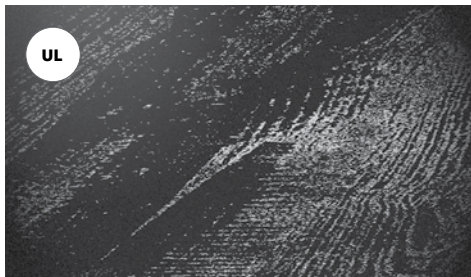

UL USED LOOK
With apparent signs of wear and tear



WG WOOD GRAIN
Rustic embossing

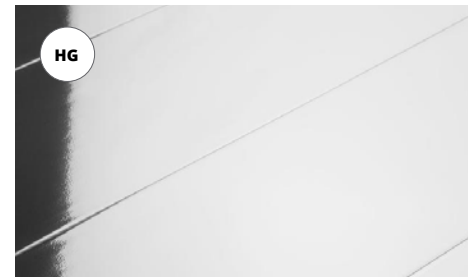

HG HIGH SHINE
High gloss mirror like finish



4V BEVEL ON ALL SIDES
The edges are bevelled on both sides and ends – for an even more vivid impression. The expert calls this "long and short side beveling".



Exclusive HARO Surfaces



EIR AUTHENTIC
Almost indistinguishable from real wood. Texture and style match perfectly. The gloss level emphasises the character and the natural look of the wood reproduction.



TEXTURED MATT
Similar to real wood grain. The matt appearance underlines the natural look.



EIR AUTHENTIC MATT
Almost indistinguishable from real wood. Texture and style match perfectly. The surface has a natural oil character. The Plank 1-Strip designs also have a slight shine effect in the pores.



SOFT MATT
Distinctive velvety soft surface. Natural and matt with a slight gloss effect in the texture.



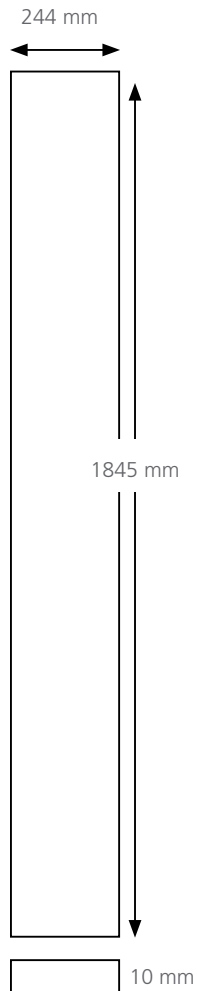

10MM MAMMUT PLUS LONG PLANK

The best and more. This is the promise of the new decors of the MAMMUT PLUS collection from Kronotex. While exhibiting the same technical mastery as all MAMMUT flooring, this offers you even more authenticity, an even larger choice of styles and even greater perfection. Apart from its incredible robustness and versatility, MAMMUT PLUS also raises the bar in other ways. Its extra-wide panels complement the existing extra-long and extra sturdy versions of the MAMMUT family. The decors seduce you with their elegantly authentic natural wood look, which cannot help but add posh country style comfort to your home.

- THICKNESS:** 10 mm
- BOARD SIZE:** 1845 X 244 X 10 mm
- BOX QUANTITY:** 4 Panels / 1.80 m²
- WARRANTY:** 30 Year Residential
- USE CLASS:** 33 / AC5 Suitable for high traffic commercial & domestic everyday use.



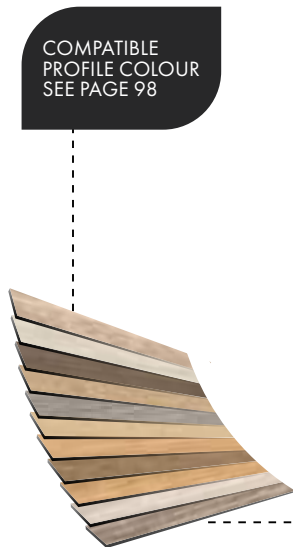

COMPATIBLE
PROFILE COLOUR
SEE PAGE 98



MACRO OAK LIGHT GREY 4V
C2212028 / D3670



MACRO OAK GREY 4V
C2212019 / D4792



MACRO OAK BEIGE 4V
C2212029 / D3669



MACRO OAK WHITE 4V
C2212027 / D4793



Our Mammut ranges now have an improved moisture guard core board which gives enhanced anti swelling performance over standard laminates. ***Not suitable for outdoor use or rooms with permanently high moisture, e.g. shower cubicles, wet rooms, saunas and rooms with floor drains.***

NOTE: Matching stair nosing available for Everest Oak Beige / Mountain Oak Grey / Mountain Oak Beige / Mountain Oak Nature & Macro Oak Brown - See Page 96



MAGNUM OAK GREY 4V
C2212053 / D4671



HIGHLAND OAK SILVER 4V
C2212026 / D4797



HIGHLAND OAK TITAN 4V
C2212022 / D4796



RESIDENCE OAK NATURE 4V
C2212054 / ML1029



MACRO OAK NATURE 4V
C2212020 / D4794



HIGHLAND OAK BRONZE 4V
C2212021 / D4795



MOUNTAIN OAK BROWN
C2212055 / D4726

10MM **MAMMUT PLUS 4V** LONG, WIDE PLANK

- THICKNESS:** 10 mm
- BOARD SIZE:** 1845 x 244 x 10 mm
- BOX QUANTITY:** 4 Panels / 1.80 m²
- WARRANTY:** 30 Year Residential
- USE CLASS:** 33 / AC5

Suitable for high traffic commercial & domestic everyday use.







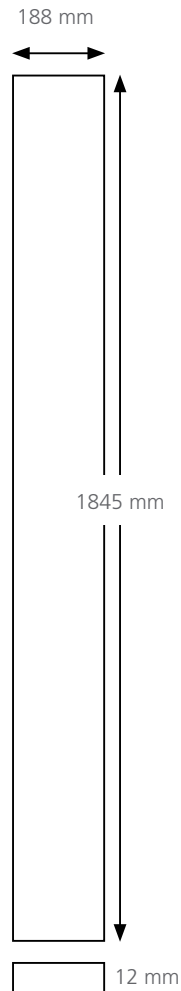

12MM MAMMUT LONG PLANK

Perfection comes in many guises and none more so than in our 12mm Mammut Long Plank from Kronotex. It combines the best features of ROBUSTO, DYNAMIC and EXQUISIT ranges. Whether used universally, for extremely heavy loads or to create a sophisticated and natural look, MAMMUT is a floor which can meet all requirements. The panels are extra hard, extra long and, what's more, extra practical. An outstanding feature of the patterns and hues is their country cottage character and the fascinating, authentic natural wood look.

- THICKNESS:** 12 mm
- BOARD SIZE:** 1845 X 188 X 12 mm
- BOX QUANTITY:** 4 Panels / 1.387 m²
- WARRANTY:** 30 Year Residential
- USE CLASS:** 33 / AC5 Suitable for high traffic commercial & domestic everyday use.





EVEREST OAK WHITE 4V

C2212014 / D3179



HIGHLAND OAK SILVER 4V

C2212031 / D4797



MACRO OAK NATURE 4V

C2212023 / D4794



MACRO OAK BROWN 4V

C2212040 / D4791



EVEREST OAK 4V

C2212010 / D3076



MOUNTAIN OAK NATURE 4V

C2212038 / D4725



MOUNTAIN OAK GREY 4V

C2212042 / D4727



Our Mammut ranges now have an improved moisture guard core board which gives enhanced anti swelling performance over standard laminates. **Not suitable for outdoor use or rooms with permanently high moisture, e.g. shower cubicles, wet rooms, saunas and rooms with floor drains.**

NOTE: Matching Stair nosing available in Highland Oak Silver / Macro Oak Beige / Macro Oak Grey / Macro Oak Nature & Macro Oak White See Page 96

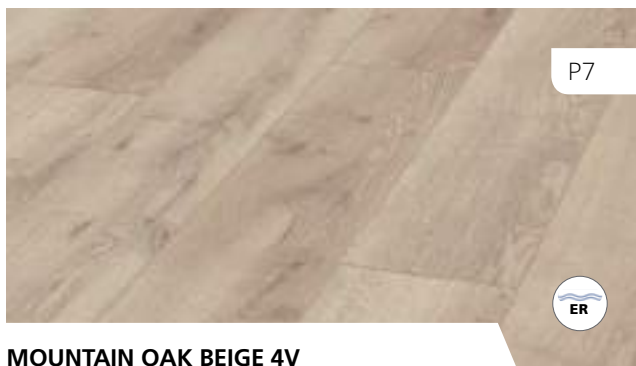

MOUNTAIN OAK BEIGE 4V

C2212043 / D4728



MACRO OAK GREY 4V

C2212039 / D4792

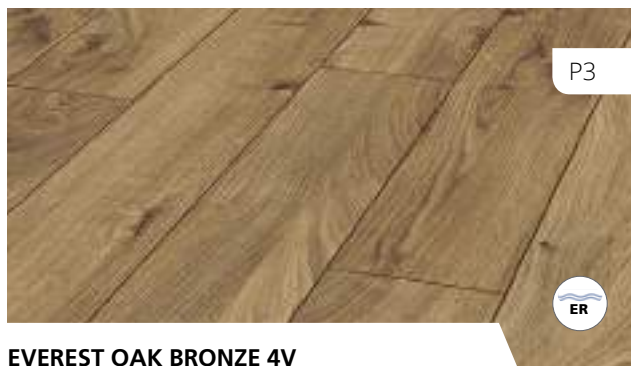

EVEREST OAK BRONZE 4V

C2212006 / D3077

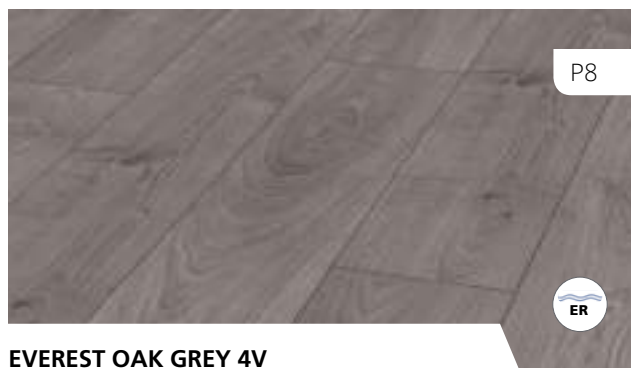

EVEREST OAK GREY 4V

C2212013 / D3178

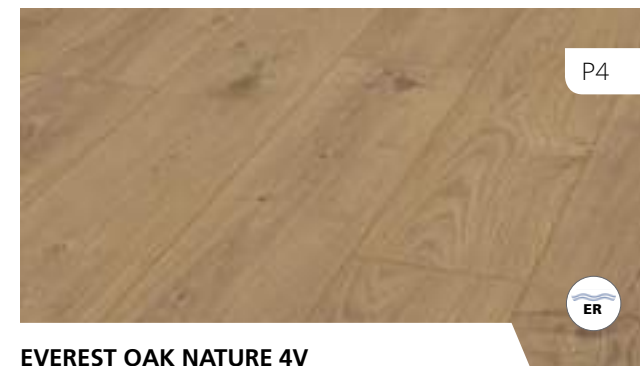

EVEREST OAK NATURE 4V

C2212009 / D4152



EVEREST OAK BEIGE 4V

C2212008 / D3081

Brochure images are representative of actual floors however may vary slightly. We always recommend visiting your local stockist to view physical samples before selection.

12MM **MAMMUT 4V** LONG PLANK

THICKNESS: 12 mm
BOARD SIZE: 1845 x 188 x 12 mm
BOX QUANTITY: 4 Panels / 1.387m²
WARRANTY: 30 Year Residential
USE CLASS: 33 / AC5

Suitable for high traffic commercial & domestic everyday use.

12MM MAMMUT MOUNTAIN OAK BEIGE

Classic aesthetics and functionality are successfully combined to create the Mammut range. Anyone who appreciates the unmistakable, natural looking appearance of oak planks and at the same time wants durability will find Mammut meets both requirements. The perfection of the manufacturing process is regarded as the benchmark for high quality laminate flooring.













TRITTY 100 GRAN VIA 4V

the greatest for your home



Extra long, extra wide, particularly authentic: a genuine trendy product with a length of 2200 mm and a width of 243 mm. Our boards in Gran Via format create an amazing, spacious appearance. The characteristic look of Gran Via planks is emphasised by bevelled edges: the edges of the planks are chamfered on all four sides. This way, the plank character is emphasised in an impressively vivid way – just like real engineered flooring.

The Gran Via 4V design makes rooms remarkably more spacious and gives them a POWERFUL RADIANCE, regardless of the style. This makes the floor a key element for an ambience of openness.

HARO Laminate Floors have double moisture protection thanks to their well balanced multilayer construction and unique aquaTec system.

- THICKNESS:** 8 mm
- BOARD SIZE:** 2200 X 243 X 8 mm
- BOX QUANTITY:** 5 Panels / 2.68 m²
- WARRANTY:** 25 Year Residential
- USE CLASS:** 32 / AC4 Suitable for medium commercial & domestic everyday use.









OAK EMILIA GREY ER C1418047

FINISH: AUTHENTIC SOFT MATT ER (HARO CODE 538770)

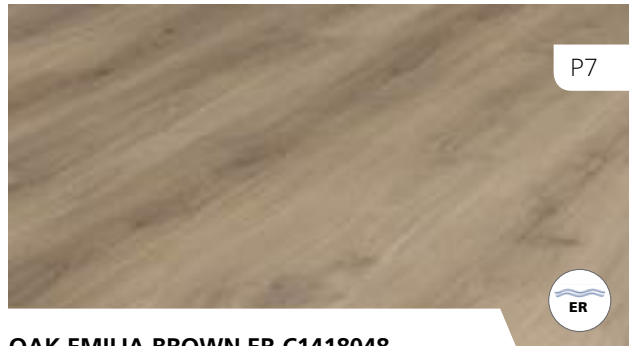

OAK EMILIA BROWN ER C1418048

FINISH: AUTHENTIC SOFT MATT ER (HARO CODE 538771)

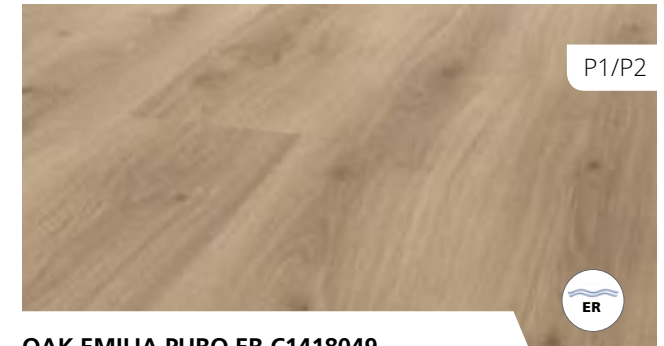

OAK EMILIA PURO ER C1418049

FINISH: AUTHENTIC SOFT MATT ER (HARO CODE 538769)

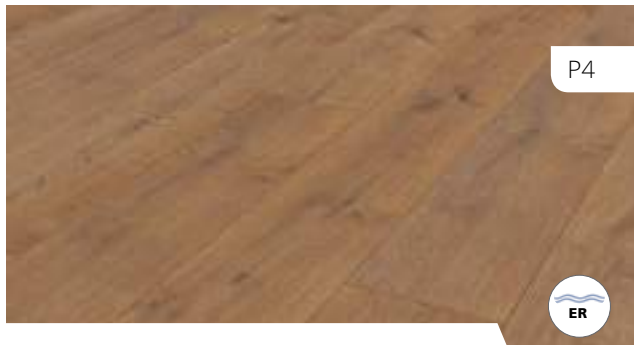

OAK PORTLAND AMBER 4V C1418030

FINISH: AUTHENTIC ER (HARO ID 533142)

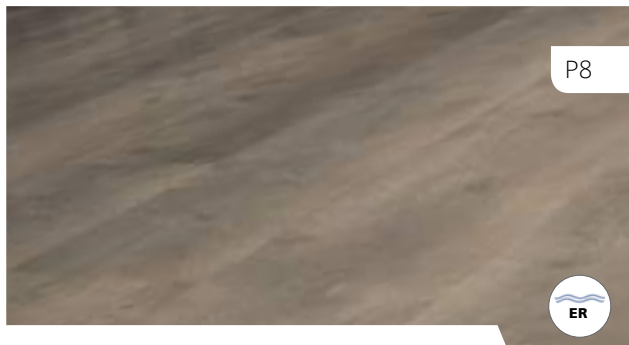

OAK BERGAMO CARBON ER C1418051

FINISH: AUTHENTIC SOFT MATT ER (HARO CODE 538767)

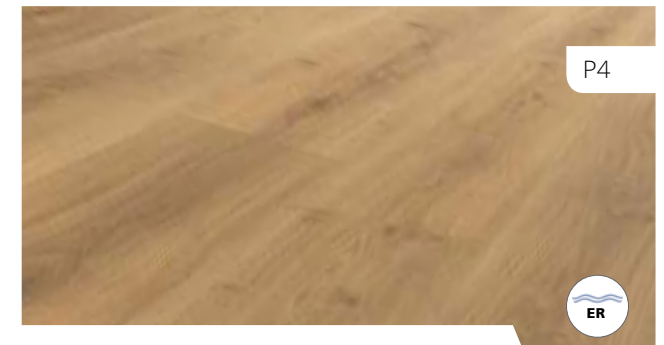

OAK EMILIA HONEY ER C1418050

FINISH: AUTHENTIC SOFT MATT ER (HARO CODE 538772)

N.B. While laminate floors are hard wearing and have a high degree of scratch resistance, they are not completely scratch proof and care should be taken to protect your floor surface. It is always beneficial to use protective felt pads under moveable furniture, chairs, table legs, doormats in entrances etc. (to protect your laminate floor against moisture, dirt and sand). Please note that wear and tear on darker coloured laminates or high shine surfaces may be more visible.



SMOKED OAK ITALICA 4V C1418020
FINISH: AUTHENTIC ER (HARO ID 530333)



OAK PORTLAND GREY 4V C1418027
FINISH: AUTHENTIC ER (HARO ID 533139)

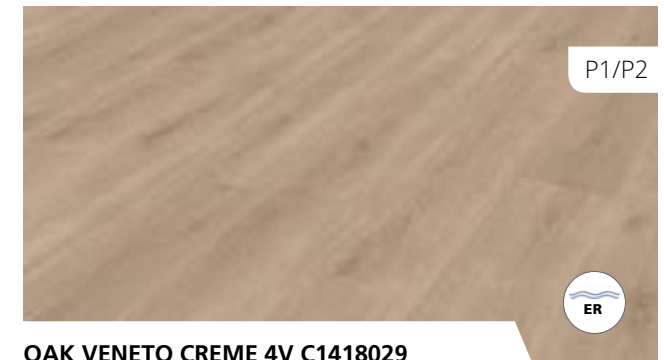

OAK VENETO CREME 4V C1418029
FINISH: AUTHENTIC MATT ER (HARO ID 535269)



VINTAGE OAK 4V C1418011
FINISH: TEXTURED MATT (HARO ID 526712)



ALPINE OAK GREY 4V C1418018
FINISH: AUTHENTIC MATT ER (HARO ID 526711)



**AQUATEC DOUBLE
MOISTURE PROTECTION**

Thanks to their well-balanced multilayer construction combined with the aquaTec edge impregnation and AquaResist core board, HARO Laminate Floors remain stable and highly resistant to moisture swelling.

Brochure images are representative of actual floors however may vary slightly. We always recommend visiting your local stockist to view physical samples before selection.

8MM
TRITTY 100
GRAN VIA 4V

- THICKNESS:** 8 mm
- BOARD SIZE:** 2200 x 243 x 8 mm
- BOX QUANTITY:** 5 Panels / 2.68 m²
- WARRANTY:** 25 Year Residential
- USE CLASS:** 32 / AC4

Suitable for medium commercial & domestic everyday use.







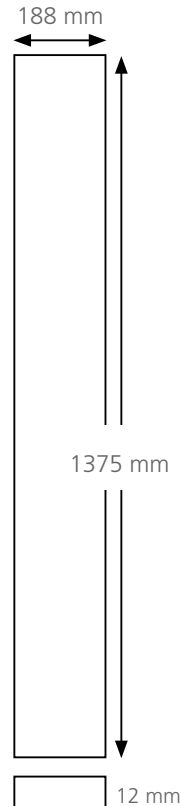

12MM ROBUSTO 4V

There are situations in life where one needs a thick skin. Where one has to be very resilient and tough. Which is why ROBUSTO is also the perfect floor for extreme levels of use. With its high-density, 12 mm thick fibreboard and an especially wear-resistant surface, it can cope with pretty much anything to which it is exposed. Even if used for commercial purposes. Its CLIC tongue-and-groove connection system will never disappoint in any situation as it was specially developed to hold up under the highest pressure.

- THICKNESS:** 12 mm
- BOARD SIZE:** 1375 X 188 X 12 mm
- BOX QUANTITY:** 5 Panels / 1.293 m²
- WARRANTY:** 30 Year Residential
- USE CLASS:** 33 / AC5 Suitable for high traffic commercial & domestic everyday use.



Our *Robusto ranges now have an improved moisture guard core board which gives enhanced anti swelling performance over standard laminates. **Not suitable for outdoor use or rooms with permanently high moisture, e.g. shower cubicles, wet rooms, saunas and rooms with floor drains.** *Excludes American Walnut.

12MM **ROBUSTO** 4V

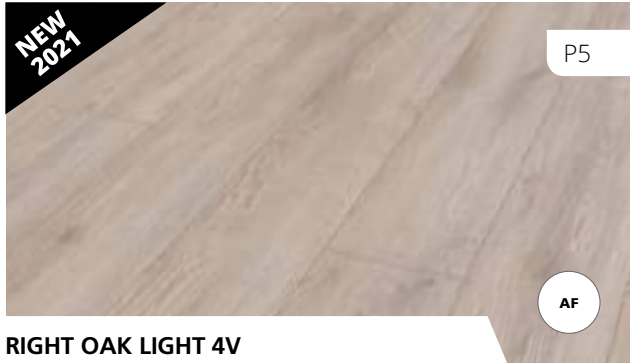

RIGHT OAK LIGHT 4V
C2210033 / D4989



PREMIUM OAK GREY 4V
C2210039 / D4956



PETTERSEN OAK BEIGE 4V
C2210011 / D4763



HARBOUR OAK WHITE 4V
C2210041 / RB1018



PREMIUM OAK NATURE 4V
C2210035 / D4955



RIP OAK NATURE 4V
C2210009 / D3180



ATLAS OAK BEIGE 4V
C2210042 / D3221



ATLAS OAK ANTHRACITE 4V
C2210043 / D3592



HIGHLAND OAK 4V
C2210002 / D2597

NOTE: Matching stair nosing available for Harbour Oak Grey / Harbour Oak / Highland Oak & Timeless Oak Grey - See Page 96



HARBOUR OAK 4V
C2210004 / D3570



PETTERSSON OAK DARK 4V
C2210015 / M1221



HARBOUR OAK GREY 4V
C2210005 / D3572



CAROLINA WALNUT 4V
C2210032 / D4520



FANTASY WOOD 4V
C2210014 / D4779



TIMELESS OAK GREY 4V
C2210010 / D3571



AMERICAN WALNUT 4V*
C2210008 (Pack Size 1.332m2)

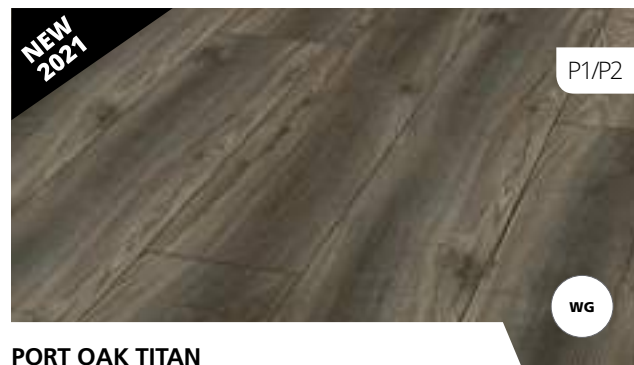

PORT OAK TITAN
C2210025 / D4610



BILBAO OAK
C2210046 / D4695









12MM ROBUSTO RIGHT OAK LIGHT

Robusto is the right choice for load bearing capacity. A high density 12 mm thick plank and 5G click system developed for maximum resistance combined with a strong wear layer makes it very hard wearing. This is a floor that can cope with the daily demands of both domestic and commercial settings while retaining it's original beauty. Robusto has fast become the popular choice for all round performance.

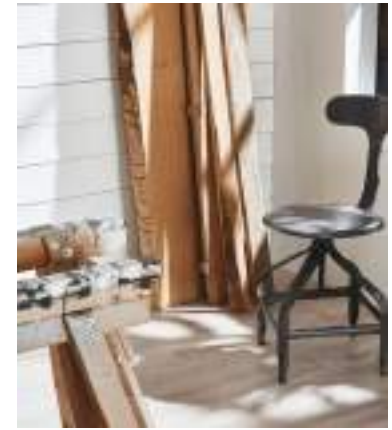





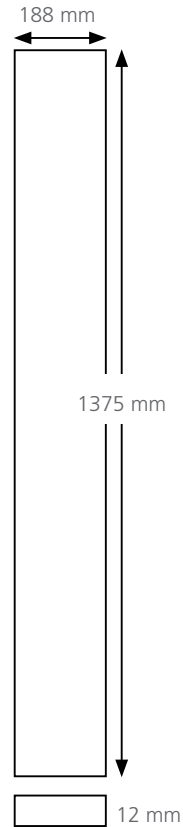

12MM EVOLUTION 4V

Luxurious, luscious and longevity are just some of the aspects of this stylish Evolution range. Contrasting styles, colours and textures, combined with a strong AC4 abrasion class and 5G Click System makes this range the perfect choice for any location.

- THICKNESS:** 12 mm
- BOARD SIZE:** 1375 X 188 X 12 mm (1.293 m² PACK)
- WARRANTY:** 25 Year Residential
- USE CLASS:** 32 / AC4 Suitable for medium commercial & domestic everyday use.







SUMMER OAK GREY 4V
C2210028 / D3900



OAK HONEY
C2210044 / D4617



Our Evolution range now has an improved moisture guard core board which gives enhanced anti swelling performance over standard laminates.
Not suitable for outdoor use or rooms with permanently high moisture, e.g. shower cubicles, wet rooms, saunas and rooms with floor drains.

12MM EVOLUTION 4V

THICKNESS: 12 mm
BOARD SIZE: 1375 X 188 X 12 mm (1.293 m² PACK)
WARRANTY: 25 Year Residential
USE CLASS: 32 / AC4
Suitable for medium commercial & domestic everyday use.



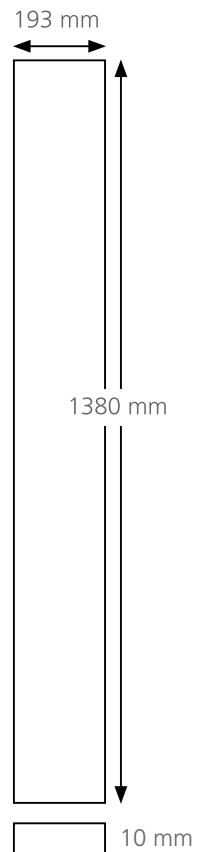

10MM METRO 4V

Our METRO range is a unique collection of specially selected decors of varying tones. A 10 mm board with a hard wearing AC4 / AC5 means the floor will stand up to the toughest demands. The range sets new trends and defines the avant-garde while creating modern classics.

THICKNESS: 10 mm

33 / AC5 Suitable for high traffic commercial & residential everyday use.

32 / AC4 Suitable for medium commercial & domestic everyday use.



*High Shine Sorrento & Tirana Hickory



OAK RUSTIKAL 4V
C1810004 / D3084



MONACO OAK 4V
C1810007 / D3863



DARK OAK 4V
C1810021 / D3774

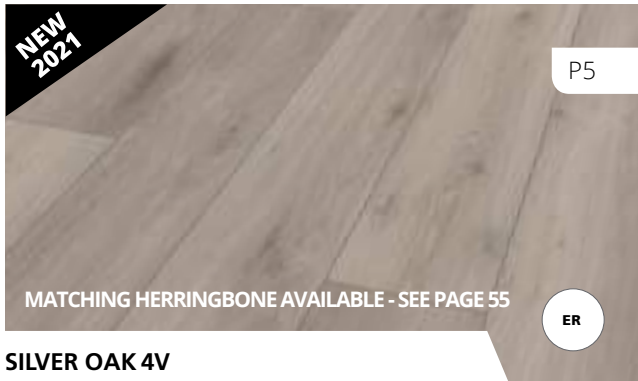

SILVER OAK 4V
C1810020 / D3773

COMPATIBLE
PROFILE COLOUR
SEE PAGE 98

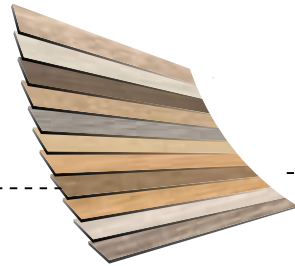

N.B. While laminate floors are hard wearing and have a high degree of scratch resistance, they are not completely scratch proof and care should be taken to protect your floor surface. It is always beneficial to use protective felt pads under moveable furniture, chairs, table legs, doormats in entrances etc. (to protect your laminate floor against moisture, dirt and sand). Please note that wear and tear on darker coloured laminates or high shine surfaces may be more visible.



CHESTNUT 4V
C1810003 / D3347



CHESTNUT NATURE 4V
C1810002 / D3344



GIRONA OAK 4V
C1810022 / M1019



Our Metro AC5 range now has an improved moisture guard core board which gives enhanced anti swelling performance over standard laminates.
Not suitable for outdoor use or rooms with permanently high moisture, e.g. shower cubicles, wet rooms, saunas and rooms with floor drains.

10MM METRO AC5 4V

THICKNESS: 10 mm
BOARD SIZE: 1380 x 193 x 10 mm
BOX QUANTITY: 6 Panels / 1.60 m²
WARRANTY: 30 Year Residential
USE CLASS: 33 / AC5

Suitable for high traffic commercial & residential everyday use.





VIENNA OAK

1380 X 193 X 10 mm 6 Panels / 1.60 m² / C1810023 / D4619
25 Year Residential Warranty



AGED ASH 4V

1285 X 192 X 10 mm 7 Panels / 1.73 m² / C1814001
20 Year Residential Warranty

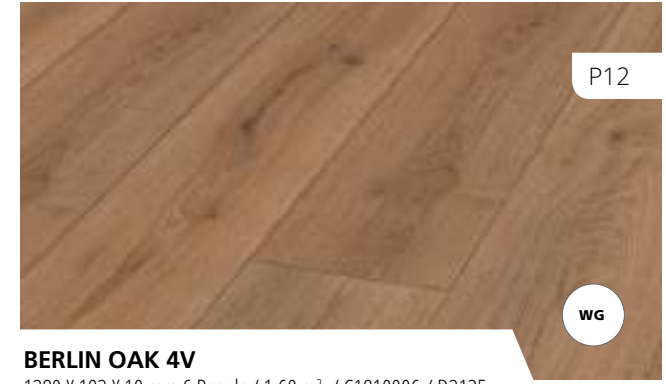

BERLIN OAK 4V

1380 X 193 X 10 mm 6 Panels / 1.60 m² / C1810006 / D3125
25 Year Residential Warranty

10MM
METRO
AC4 4V

USE CLASS: 32 / AC4 Suitable for medium commercial & domestic everyday use.





TIRANA HICKORY 4V HIGH SHINE FINISH
 1380 X 159 X 10 mm 8 Panels / 1.76 m² / C1813003
 25 Year Residential Warranty

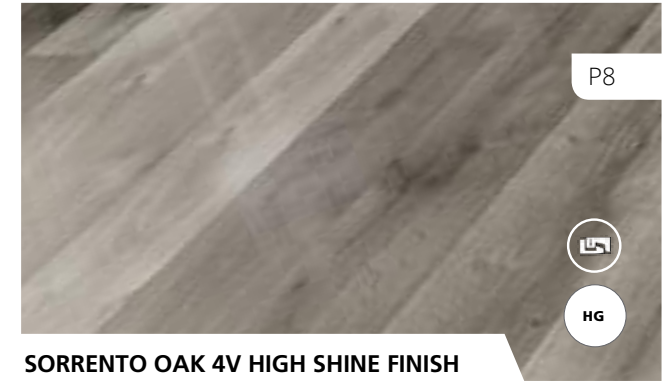

SORRENTO OAK 4V HIGH SHINE FINISH
 1380 X 159 X 10 mm 8 Panels / 1.76 m² / C1813005
 25 Year Residential Warranty



DROP LOCK SYSTEM

Our Sorrento Oak & Tirana Hickory floors feature a "drop lock" click system.

We do not recommend underlays thicker than 3mm for these floors.

N.B. While laminate floors are hard wearing and have a high degree of scratch resistance, they are not completely scratch proof and care should be taken to protect your floor surface. It is always beneficial to use protective felt pads under moveable furniture, chairs, table legs, doormats in entrances etc. (to protect your laminate floor against moisture, dirt and sand). Please note that wear and tear on darker coloured laminates or high shine surfaces may be more visible.



10MM
METRO
HIGH SHINE

THICKNESS: 10 mm
BOARD SIZE: 1380 x 159 x 10 mm
BOX QUANTITY: 8 Panels / 1.76 m²
WARRANTY: 25 Year Residential
USE CLASS: 32 / AC4

Suitable for medium commercial & residential everyday use.



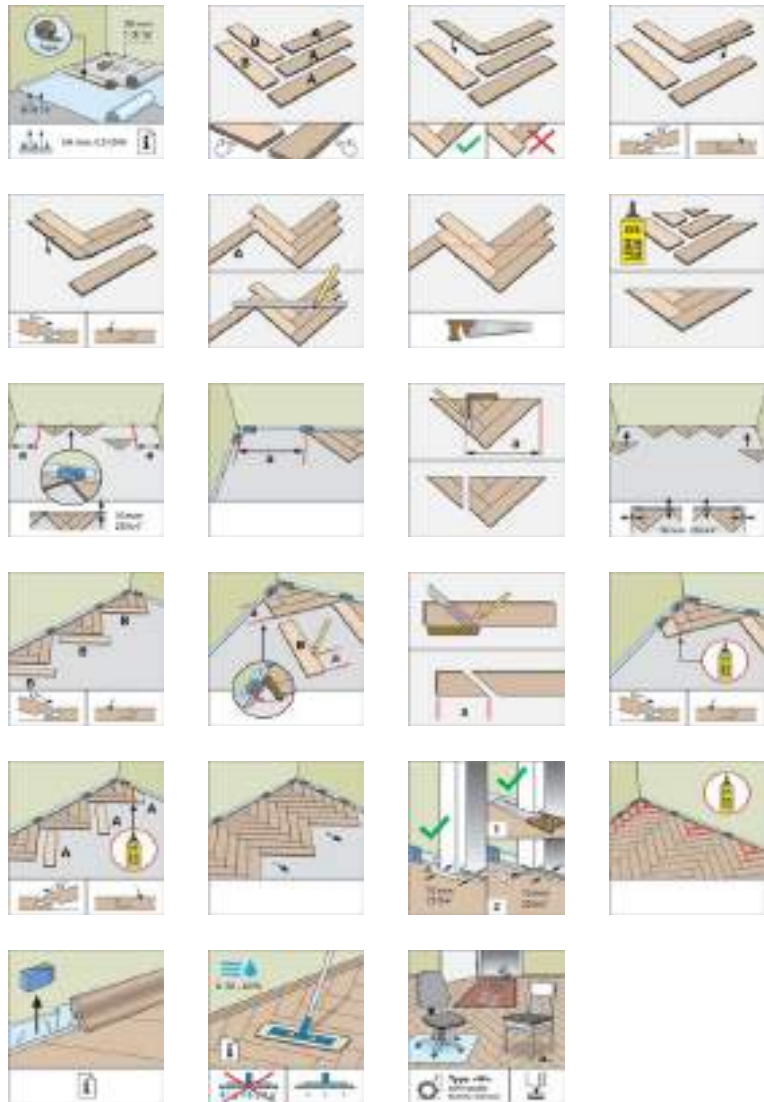

8MM HERRINGBONE LAMINATE

The classic Herringbone design can be traced back to the Romans who used the design in the construction of roads to add strength. The pattern became known as "Herring - Bone" as it resembles the outline of a fish skeleton. The Renaissance periods between the 14th and 17th centuries saw the design being used in many aspects of architectural design including flooring.

Traditional real wood Herringbone has long been a desirable choice to add a touch of class to any room or entrance hallway. Laminate manufacturing expertise has now been developed to bring you a high quality affordable alternative.

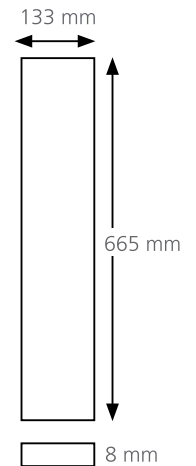

- THICKNESS:** 8 mm
- BOARD SIZE:** 665 X 133 X 8 mm
- BOX QUANTITY:** 14 Panels / 1.238 m²
- WARRANTY:** 25 Year Residential
- USE CLASS:** 32 / AC4 Suitable for medium commercial & domestic everyday use.
- INSTALLATION:** Valinge Click System





CALAIS OAK HERRINGBONE
665 x 133 x 8 mm / 1.238 m² / C1610017 / D4766
25 Year Residential Warranty



BORDEAUX OAK HERRINGBONE
665 x 133 x 8 mm / 1.238 m² / C1610013 / D3516
25 Year Residential Warranty

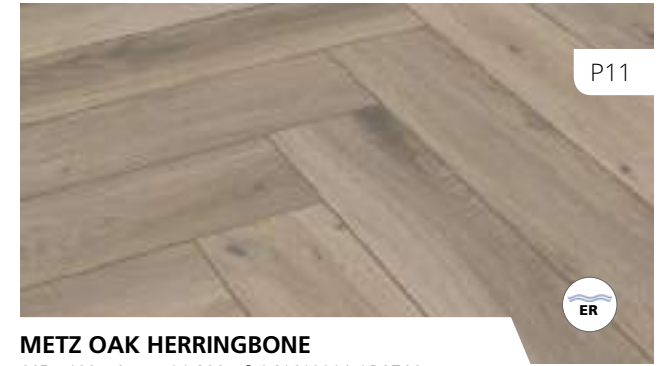

METZ OAK HERRINGBONE
665 x 133 x 8 mm / 1.238 m² / C1610014 / D3766
25 Year Residential Warranty



Our **Herringbone** ranges now have an improved moisture guard core board which gives enhanced anti swelling performance over standard laminates. *Not suitable for outdoor use or rooms with permanently high moisture, e.g. shower cubicles, wet rooms, saunas and rooms with floor drains.*

25 YEAR WARRANTY

MATCHING PLANKS

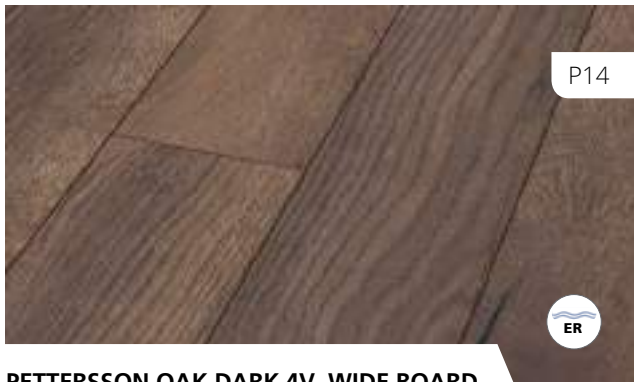

PETTERSSON OAK DARK 4V WIDE BOARD
1380 x 244 x 8 mm / 2.694 m² box / C1413010 / D4766
25 Year Residential Warranty



POLAR OAK 4V
1380 x 193 x 8 mm / 2.131 m² box / C1410003 / D3516
25 Year Residential Warranty



WELLS OAK 4V
1380 x 193 x 8 mm / 2.131 m² box / C1411033 / D3766
25 Year Residential Warranty



SILVER OAK HERRINGBONE

665 x 133 x 8 mm / 1.238 m² / C1610020 / D3773
25 Year Residential Warranty



FERRARA OAK HERRINGBONE

665 x 133 x 8 mm / 1.238 m² / C1610015 / D3860
25 Year Residential Warranty



PISA OAK HERRINGBONE

665 x 133 x 8 mm / 1.238m² / C1610016 / D3861
25 Year Residential Warranty

25 YEAR WARRANTY

MATCHING PLANKS



SILVER OAK PLANK 4V

1380 x 193 x 10 mm / 1.6 m² box / C1810020 / D3773
30 Year Residential Warranty



DERBY OAK 4V

1380 x 193 x 8 mm / 2.131 m² box / C1411032 / D3860
25 Year Residential Warranty



CARLTON OAK 4V

1380 x 193 x 8 mm / 2.131 m² box / C1411031 / D3861
25 Year Residential Warranty







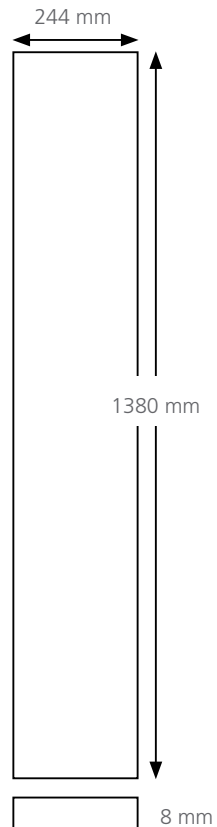

8MM EXQUISIT PLUS WIDE 244MM

Exquisit Plus Wide 4V - 244mm wide boards give an expansive feel to any room. Spaciousness and elegance go hand in hand to create an exquisite ambience. Exquisit plus wide 4V floors feature embossed in register surfaces for that realistic wood look from a laminate floor. Exquisit plus wide features a 4V four way bevel on all edges.

- THICKNESS:** 8 mm
- BOARD SIZE:** 1380 X 244 X 8 mm
- BOX QUANTITY:** 8 Panels / 2.694 m²
- WARRANTY:** 25 Year Residential
- USE CLASS:** 32 / AC4 Suitable for medium commercial & domestic everyday use.





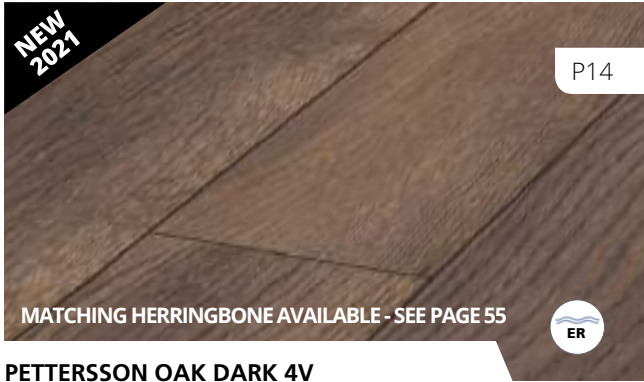

PETTERSSON OAK DARK 4V
C1413010 / D4766



RECLAIMED OAK / HARBOUR OAK 4V
C1413001 / D3570



BARN OAK / HARBOUR OAK GREY 4V
C1413002 / D3572

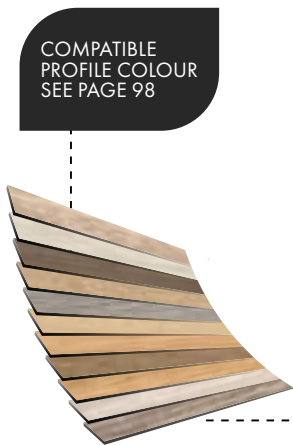

MADRID OAK 4V
C1413018 / D4694



PETTERSSON OAK NATURE 4V
C1413005 / D4764

8MM
EXQUISIT PLUS WIDE 4V
244MM

- THICKNESS:** 8 mm
- BOARD SIZE:** 1380 x 244 x 8 mm
- BOX QUANTITY:** 8 Panels / 2.694 m²
- WARRANTY:** 25 Year Residential
- USE CLASS:** 32 / AC4

Suitable for medium commercial & domestic everyday use.





8MM EXQUISIT PLUS WIDE 4V

Wide plank floors are a real classic that never lose their appeal. Our Exquisit collection brings this traditional charm to your home with its unique 244 mm wide board. Exquisit radiates cosiness every day with a natural appearance of solid wood. Thanks to the embossed wood grain effect the floor is both elegant and authentic.



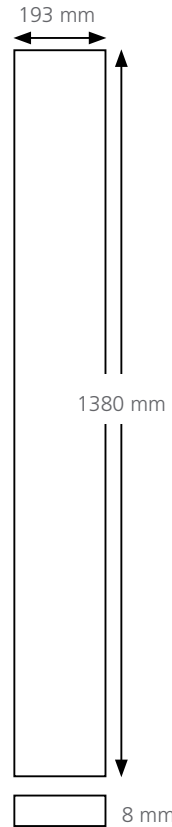

8MM DYNAMIC

A floor with which you can express your entire individuality. DYNAMIC 4V can be used anywhere, is extremely resilient and above all else, offers a unique variety of patterns and hues. Whether you choose the rich, dark hues of Augusta Walnut or the traditional tones of Irish Oak, you will be assured of a stunning floor whose performance matches its good looks. DYNAMIC 4V features a 4V four way bevel on all edges.

- THICKNESS:** 8 mm
- BOARD SIZE:** 1380 X 193 X 8 mm
- BOX QUANTITY:** 8 Panels / 2.131 m²
- WARRANTY:** 25 Year Residential
- USE CLASS:** 32 / AC4 Suitable for medium commercial & domestic everyday use.

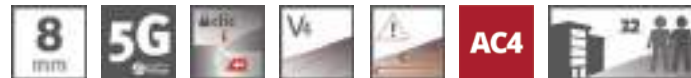





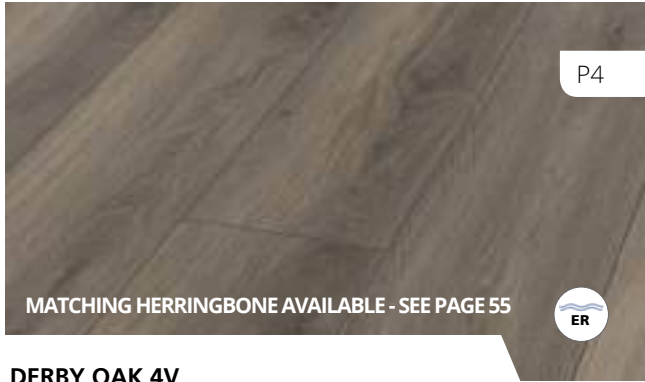

DERBY OAK 4V
C1411032 / D3860

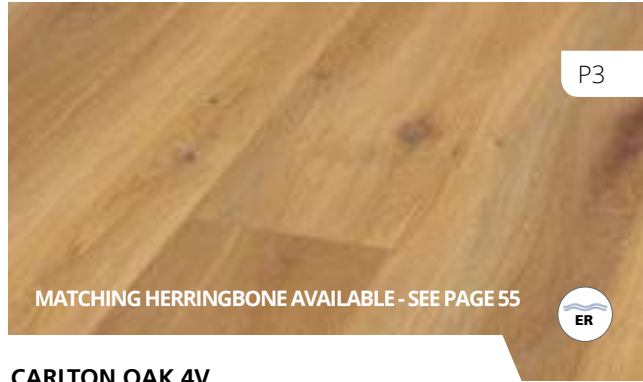

CARLTON OAK 4V
C1411031 / D3861



BRACKEN OAK 4V
C1411008 / D3221

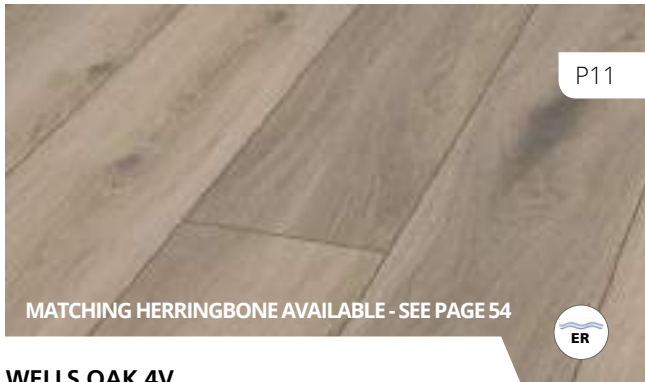

WELLS OAK 4V
C1411033 / D3766



PORT OAK GREY 4V
C1410019 / D4612



NORDIC OAK 4V
C1411011 / D3223



OAK RENÉ GREY 4V
C1411035 / D3864



PORT OAK 4V
C1410018 / D4609

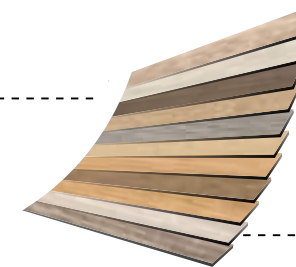

COMPATIBLE
PROFILE COLOUR
SEE PAGE 98



SMOKED OAK 4V
C1411009 / D3220



MISSOURI WALNUT 4V
C1411029 / D4520



BRUNSWICK OAK 4V
C1411030 / D3572



OAK CHATELET 4V
C1410011 / D4754



IRISH OAK 4V
C1411005 / D2597



AUGUSTA WALNUT 4V
C1411022 / D2562

8MM DYNAMIC 4V

THICKNESS: 8 mm
BOARD SIZE: 1380 X 193 X 8 mm
BOX QUANTITY: 8 Panels / 2.131m²
WARRANTY: 25 Year Residential
USE CLASS: 32 / AC4
Suitable for medium commercial & domestic everyday use.







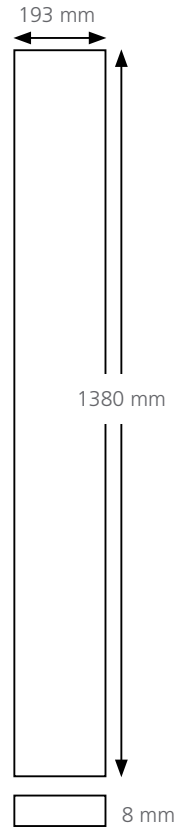

8MM EXCEL 4V

The EXCEL 4V range will win you over with its unique range of three brand new decors. 8 mm boards with AC4 abrasion class rating can be used throughout the home, bringing a natural and durable wood look to your home's spaces. Floors that are made to be enjoyed for a long time. EXCEL 4V features a 4V four way bevel on all edges.

- THICKNESS:** 8 mm
- BOARD SIZE:** 1380 X 193 X 8 mm
- BOX QUANTITY:** 8 Panels / 2.131 m²
- WARRANTY:** 25 Year Residential
- USE CLASS:** 32 / AC4 Suitable for medium commercial & domestic everyday use.

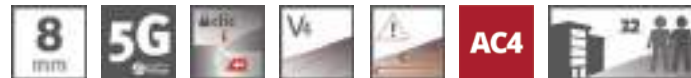





BREWERY OAK 4V
C1410001 / D3125



PORTER OAK 4V
C1410002 / D3530

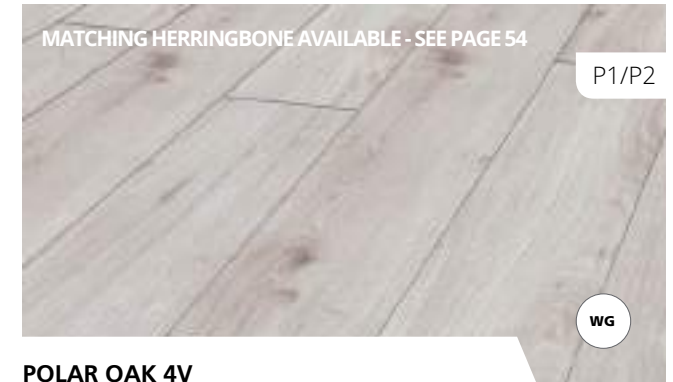

POLAR OAK 4V
C1410003 / D3516

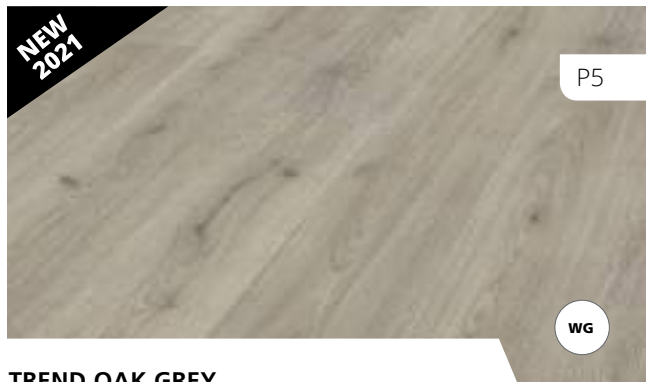

TREND OAK GREY
C1410017 / D3126

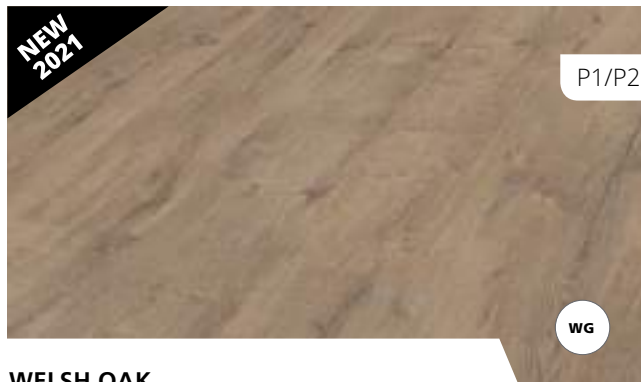

WELSH OAK
C1410020 / D4616

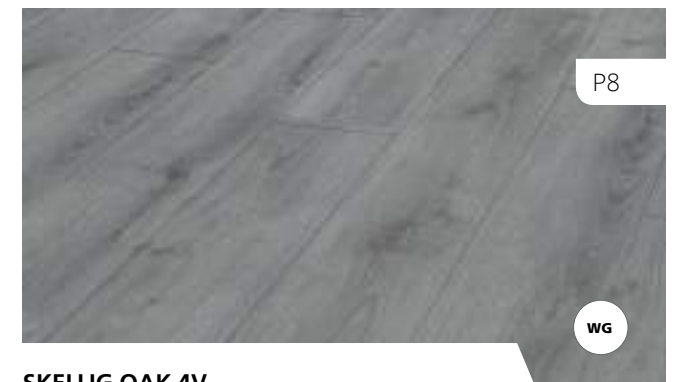

SKELLIG OAK 4V
C1410012 / D3900

8MM
EXCEL
4V

THICKNESS: 8 mm
BOARD SIZE: 1380 X 193 X 8 mm
BOX QUANTITY: 8 Panels / 2.131m²
WARRANTY: 25 Year Residential
USE CLASS: 32 / AC4

Suitable for medium commercial & domestic everyday use.



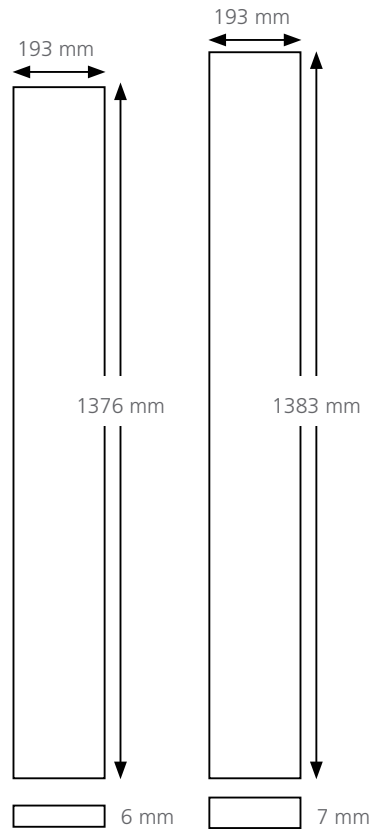

6MM & 7MM

Enjoy decorating your home to your own individual tastes. A SMART laminate floor features an outstanding price/performance ratio. The warmth and look of a real wood floor with the reliability and convenience of a laminate floor. The SMART range features a plank, a two strip and one 3-strip decors. All floors in the SMART range are square edge. Excellent value combined with warm, inviting wood decors make SMART a wise choice for any home. A price conscious and classic choice for your room that does not compromise on style or elegance. The SMART 4V range features three attractive oak plank decors. SMART 4V features a 4V four way bevel on all edges.

- THICKNESS:** 6 & 7 mm
- BOARD SIZE:** 1376 X 193 X 6 mm
1383 X 193 X 7 mm
- BOX QUANTITY:** 6MM 11 Panels / 2.921m²
7MM 9 Panels / 2.397m²
- WARRANTY:** 6 mm 6 Year Residential
7 mm 20 Year Residential
- USE CLASS:** 23 / AC3 (6 mm) *Suitable for high traffic domestic everyday use.*
31 / AC3 (7 mm) *Suitable for light commercial & domestic everyday use.*







SUMMER OAK NATURE 4V
C1211007 / D3903



BURREN OAK 4V
C1211008 / D3532



ORMOND OAK 4V
C1211003 / D3531



TARA OAK 4V
C1211010 / D3904

7MM
SMART
4V

THICKNESS: 7 mm
BOARD SIZE: 1383 X 193 X 7mm
BOX QUANTITY: 9 Panels / 2.397 m²
WARRANTY: 20 Year Residential
USE CLASS: 31 / AC3
Suitable for light commercial
& domestic everyday use.





TICINO WALNUT 3-STRIP
C1210002 / D1440

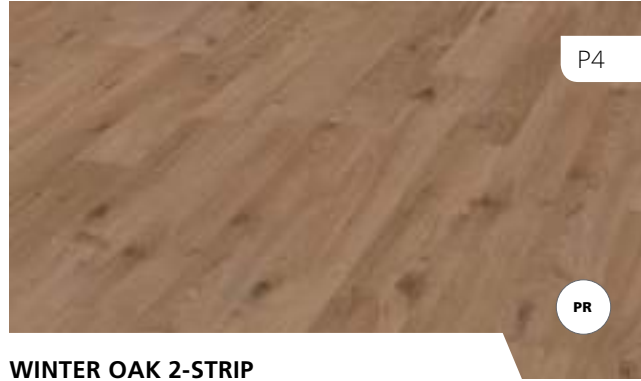

WINTER OAK 2-STRIP
C1220007 / D5263



OAK GREY 2 STRIP
C1220008 / D5262

7MM
SMART
SQUARE EDGE

- THICKNESS:** 7 mm
 - BOARD SIZE:** 1383 X 193 X 7 mm
 - BOX QUANTITY:** 9 Panels / 2.397 m²
 - WARRANTY:** 20 Year Residential
 - USE CLASS:** 31 / AC3
- Suitable for light commercial
& domestic everyday use.





6MM SUMMER OAK LIGHT GREY
C1010006 / D3904



6MM TREND OAK
C1010002 / D3125

6MM **SQUARE** EDGE

THICKNESS: 6 mm
BOARD SIZE: 1376 X 193 X 6 mm
BOX QUANTITY: 11 Panels / 2.921 m²
WARRANTY: 6 Year Residential
USE CLASS: 23 / AC3
Suitable for high traffic domestic everyday use.



HARO
Quality Flooring

*New Generation Flooring
suitable for Kitchens & Bathrooms.
No underlay is required,
manufactured with integrated
Cork Underlay which reduces room
and footfall sound as well as
optimised walking comfort.*

HARO Disano Classic Aqua / **Field Oak Textured** - See Page 87

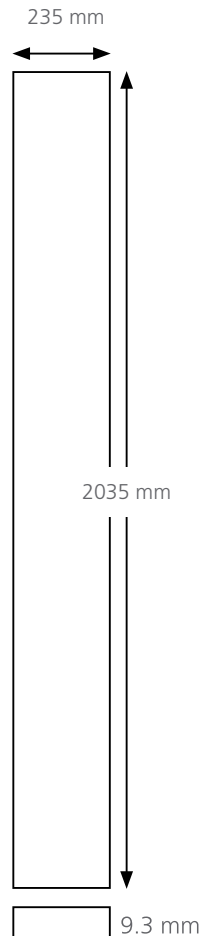

9.3MM DISANO AQUA CLASSIC



The moisture resistant design floor for healthy living.

Disano Floors are right on trend and combine the positive features of engineered and laminate floors. They are soft, warm underfoot, hard-wearing, easy-care, quiet - and in addition, they promote healthy living. They are free of PVC, plasticizers, and phthalates and have received the Blue Angel label and Eco seal. Thanks to the additional ElastoTec layer, DISANO Classic provides a pleasantly soft walking feeling. The AquaReject core board based on natural materials is particularly resistant against swelling, making it a great alternative to tiles in bathrooms or kitchens. **The only requirement is glue-down installation in kitchens and bathrooms for water resistant rating.** DISANO Classic Aqua is available in lively, vibrant styles as well as classic, elegant colour variants.

- THICKNESS:** 9.3 mm
- BOARD SIZE:** 2035 X 235 X 9.3 mm
- BOX QUANTITY:** 5 Panels / 2.39 m²
- WARRANTY:** 25 Year Residential
- USE CLASS:** 33 / AC5 Suitable for high traffic commercial & domestic everyday use.





A moisture resistant high density fibreboard (HDF) with built in cork underlay and durable decorative surface.

DISANO Classic Aqua in trendy Plank 1-Strip format can also be installed in wet rooms (A0) if glued down. With its AquaReject core board based on natural materials it is especially resistant to moisture.

Soft and durable decorative surface layer

Authentic wood appearance. The surface layer is resilient, soft and pleasantly warm, protects the floor and ensures excellent durability and ease of maintenance. Resistant to fading under UV light – no colour change.

Pressure Distribution Layer

Semi-flexible, water-resistant and free from PVC and plasticisers. The ElastoTec layer provides additional elasticity and walking comfort. It protects the floor from dents and penetrating moisture while ensuring improved stability.

Core board with moisture protection (5 mm)

The AquaReject core board based on natural materials is particularly resistant against swelling. This is why DISANO Classic Aqua is also suitable for glue-down installation in damp rooms (A0).

Integrated cork insulation underlay

High-density cork insulation underlay for room and footfall sound reduction as well as for optimum walking comfort (1.2mm). No additional insulation underlay needed. Suitable for use with underfloor heating: Thermal resistance 0.063 m² K/W.



OAK VINTAGE GREIGE RUSTIQUE TEXTURED 4V
C1418035 (HARO ID 536249)



COUNTRY OAK GREY RUSTIQUE TEXTURED 4V
C1418042 (HARO ID 536251)



WILD OAK TEXTURED 4V
C1418041 (HARO ID 535700)

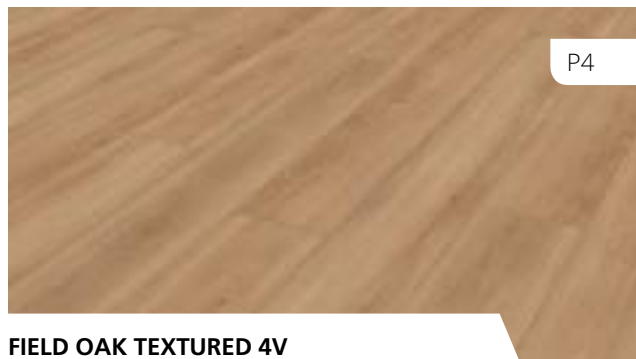

FIELD OAK TEXTURED 4V
C1418040 (HARO ID 536247)



CRYSTAL OAK TEXTURED 4V
C1418043 (HARO ID 536242)

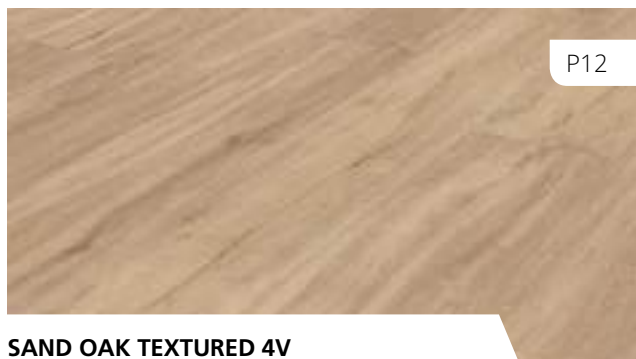

SAND OAK TEXTURED 4V
C1418038 (HARO ID 535703)

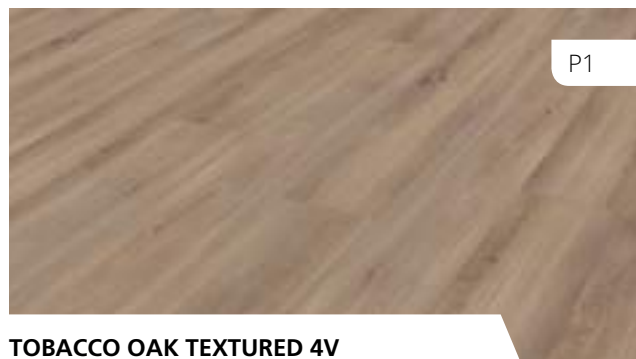

TOBACCO OAK TEXTURED 4V
C1418044 (HARO ID 536248)

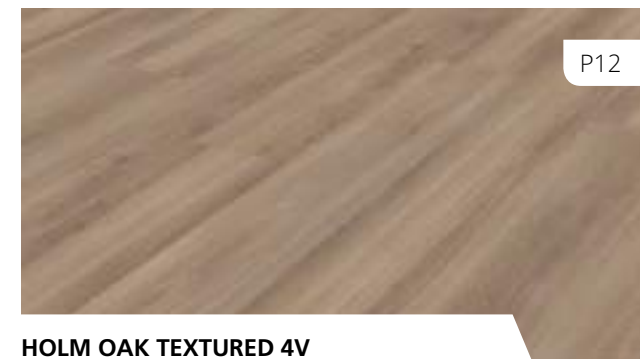

HOLM OAK TEXTURED 4V
C1418039 (HARO ID 535699)

Note: It is very important that this product is acclimatised for 3 days prior to installing. This will allow the ElastoTec Layer to adjust. Please follow full installation details.

9.3MM DISANO AQUA CLASSIC

THICKNESS: 9.3 mm
BOARD SIZE: 2035 x 235 x 9.3 mm
BOX QUANTITY: 5 Panels / 2.39 m²
WARRANTY: 25 Year Residential
USE CLASS: 33 / AC5

Suitable for high traffic commercial & domestic everyday use.





Underlays



Underlay is the foundation to all professional floor installations therefore it is essential that the correct product is specified to suit conditions and customer expectations of performance. We recommend using a good quality underlay for all hard subfloors, whether they are made of cement, wood substrate, ceramic or synthetic. You consequently increase the resilience of the floor, absorb indoor and footfall sound and level minor irregularities in the subfloor. We recommend that you use polythene over concrete subfloors in addition to underlay.

Note: Always sweep and clean floor before placing the underlay down.



Name	2mm White Foam	2mm Cork	2mm Heat Master Perforated	3mm Acoustic Blue
Code	F1010035 / F1010030	F1010004	F1010014	F1010007
Coverage Per Roll/Pack	15 / 25m ²	20m ²	10m ²	10m ²
Roll Size	3mm x 1m x 15 / 25m	2mm x 1m x 20m	2mm x 1m x 10m	3mm x 1m x 10m
TOG Rating	0.62	0.41	0.35	0.88
Impact Sound Reduction	16dB	17dB	20dB	22dB
Underfloor Heating	✗ Do not use	✓ Do not use	✓	✓ ≤ 8mm Laminate only
Compressive Strength	Poor	Good	Very Good	Very Good
Heat Transfer Resistance	0.062 k/w m ²	0.041 k/w m ²	0.035 k/w m ²	0.088 k/w m ²
Rolls per Pallet	64 / 48	24	72	56

*Contact our technical department for more information.

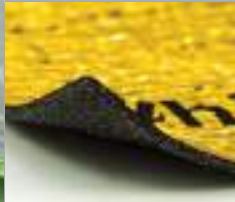
	 New	 New		
3mm Ultra Strong	3mm Sound Master Pro Cork Rubber Underlay	4.5mm Sound Master Pro Cork Rubber Underlay	3mm Silent Plus	3mm Gold Plus Premium
F1010015	F1010018	K1010024	F1010011	F1010017
10m ²	10m ²	10m ²	10m ²	15m ²
3mm x 1m x 10m	3mm x 1m x 10m 🔒 Roll weight: 22kg	4.5mm x 1m x 10m 🔒 Roll weight: 33kg	3mm x 1m x 10m	4mm x 1m x 15m
0.60	0.75	0.37	1.20	0.90
22dB	18dB	Depends on applications*	23dB	20dB
✓ ≤ 8mm Laminate only	✓ ≤ 8mm Laminate only	✓	✗ Do not use	✗ Do not use
Excellent	Excellent	Excellent	Very Good	Good
0.060 k/w m ²	0.075 k/w m ²	0.037 m k/w k/w m ²	0.120 k/w m ²	0.090 k/w m ²
48	40	40	30 / 36	48

*Contact our technical department for more information.





RE VITA LIZE

YOUR HOME

Timber floors need a minimum 10mm expansion gap around all edges where the floor is meeting skirting or fixed structures such as kitchen islands. This is essential for natural movement of the floor as room temperatures change throughout the year. The quick fix DIY solution is to leave a gap at existing skirting and cover with a small angled piece of timber known as "scotia". The professional installer and discerning home owner will take the opportunity to add another dimension to their project by replacing the skirting and cutting the base of the door frame. This effectively allows the floor to float under the skirting and door frame for a flawless finish and makes installation easier.



169 X 18 X 4200 mm WHITE
GEORGIAN
SKIRTING PRIMED



144 X 18 X 4200 mm WHITE
DOUBLE SHAKER
SKIRTING PRIMED



94 X 18 X 2200 mm WHITE
GEORGIAN
ARCHITRAVE PRIMED



94 X 18 X 2200MM WHITE
DOUBLE SHAKER
ARCHITRAVE PRIMED



WHITERIVER WHITE PRIMED
GEORGIAN

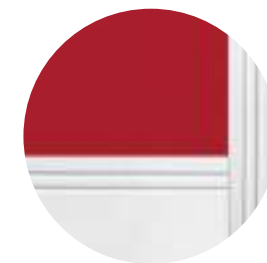

WHITERIVER WHITE PRIMED
DOUBLE SHAKER

White Primed Skirting & Architrave Options

White primed skirting and architrave continue to grow in popularity. Each length is pre-primed ready for you to add your own finish. Choose crisp white for clean lines or contemporary shades to match surrounding decors. Our profiles are made from moisture-resistant MDF.



144 X 18 X 4200 mm WHITE
MOULDED
SKIRTING PRIMED
H1010004



144 X 18 X 4200 mm WHITE
CHAMFERED
SKIRTING PRIMED
H1010002



144 X 18 X 4200 MM WHITE
SHAKER
SKIRTING PRIMED
H1010009



144 X 18 X 4200 mm WHITE
CONTEMPORARY
SKIRTING PRIMED
H1010025



180/210 X 22 X 4200 mm WHITE
VICTORIAN
SKIRTING PRIMED
H1010006/H1010015



180 X 22 X 4200 mm WHITE
GRANGE
SKIRTING PRIMED
H1010008



69/94 X 18 X 2200 mm WHITE
MOULDED
ARCHITRAVE PRIMED
H1010003



78/94 X 18 X 2200MM WHITE
CHAMFERED
ARCHITRAVE PRIMED
H1010016/H1010001



94 X 18 X 2200 mm WHITE
SHAKER
ARCHITRAVE PRIMED
H1010010



94 X 18 X 2200 mm WHITE
CONTEMPORARY
ARCHITRAVE PRIMED
H1010026



94 X 22 X 2200 mm WHITE
VICTORIAN
ARCHITRAVE PRIMED
H1010005



94 X 22 X 2200 mm WHITE
GRANGE
ARCHITRAVE PRIMED
H1010007



WHITERIVER WHITE PRIMED
MOULDED



WHITERIVER WHITE PRIMED
CHAMFERED



WHITERIVER WHITE PRIMED
SHAKER

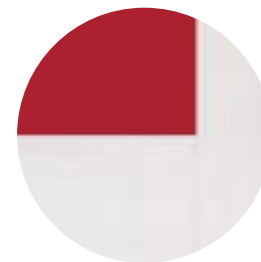

WHITERIVER WHITE PRIMED
CONTEMPORARY



WHITERIVER WHITE PRIMED
VICTORIAN



WHITERIVER WHITE PRIMED
GRANGE

PRE FINISHED ACCESSORIES

SKIRTING BOARDS

Our pre-finished foil wrapped skirting's come in 2.4 m lengths and are perfect for replacing old skirting while the 16 mm scotia's are the ideal size for covering expansion gaps should you wish to leave existing skirting in place. Full range of matching scotia are also available for this range.



WALNUT

120 X 15 X 2400 mm

F1411004



SOLID GREY

120 X 15 X 2400 mm

F1411005



LIGHT GREY

120 X 15 X 2400 mm

F1411009

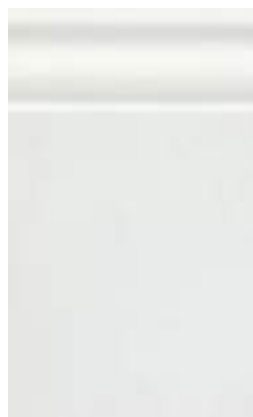

WHITE

120 X 15 X 2400 mm

140 X 18 X 2400 mm

F1411003 / F1411007



NATURAL OAK

120 X 15 X 2400 mm

140 X 18 X 2400 mm

F1411002 / F1411006

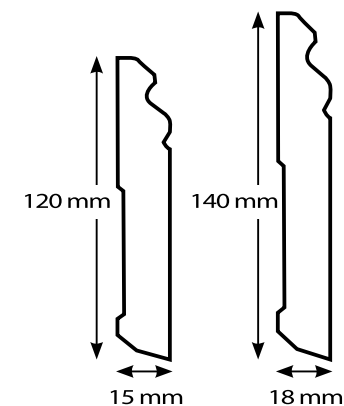

SCOTIA

FOIL WRAPPED SCOTIA DIMENSIONS: 16 X 16 X 2400 mm

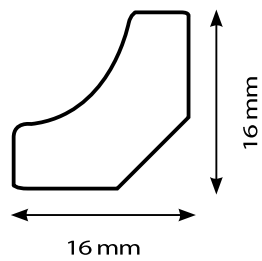

NATURAL OAK
F1410003



WALNUT
F1410007



SMOKED OAK
F1410008



BEIGE OAK
F1410009

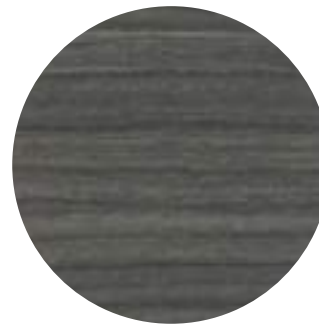

SOLID GREY
F1410012

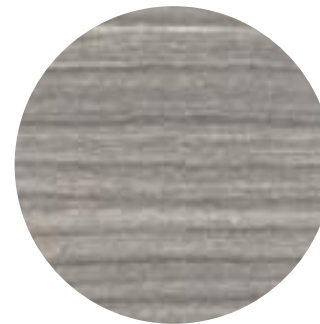

LIGHT GREY
F1410011



LIGHT OAK
F1410010

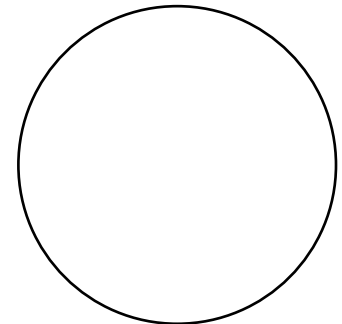

WHITE
F1410004

LAMINATE STAIR NOSING SOLUTIONS

Wooden stairs are in line with the latest interior design trends. Puristic furniture and large glass areas correspond with floors, walls and stairs that radiate warmth and provide texture. Our Stair Nosing are made from matching planks. Available ex stock.

	Code	Length
12mm Robusto		
Harbour Oak Grey	C3000001	1300mm
Harbour Oak	C3000051	1300mm
Highland Oak	C3000100	1300mm
Timeless Oak Grey	C3000151	1300mm
10mm Mammut		
Highland Oak Silver	C3000301	1800mm
Macro Oak Beige	C3000351	1800mm
Macro Oak Grey	C3000401	1800mm
Macro Oak Nature	C3000451	1800mm
Macro Oak White	C3000501	1800mm
12mm Mammut		
Everest Oak Beige	C3000700	1800mm
Mountain Oak Grey	C3000731	1800mm
Mountain Oak Beige	C3000750	1800mm
Mountain Oak Nature	C3000800	1800mm
Macro Oak Brown	C3000830	1800mm



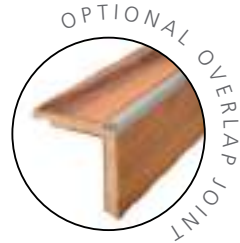

HARO offer an ideal solution to individually match each of their floor decors for contemporary interior stair design. Choose between flush connection on stair tread and riser or traditional overlap joint on riser.

HARO Tritty 100 Gran Via Stair Nosing 8mm

- 60 x 60 x 2180 mm - Click engages both sides.
- Re-enforced aluminium corner.
- **4 - 5 week lead time.**
- Precision solution for a seamless appearance.
- Available to special order alternatively with overlap joint on riser. Must be specified at time of ordering.

Commercial Two Part Profile

Precision German manufacturing ensures a professional finish for all applications. The base section is secured to the substrate with screws while the top section sits between the tread and riser for a truly robust finish. Matt silver.



Euro Step Stair Nosing 320

Silver 2700 mm
Suitable for 7 mm - 16 mm laminates
F1625043

FINISHING TOUCHES

Flooring Profiles

BY WHITERIVER

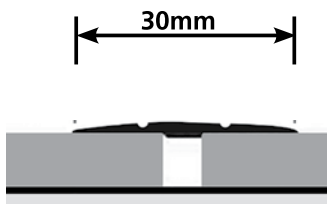
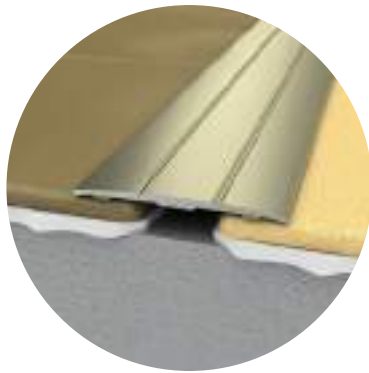
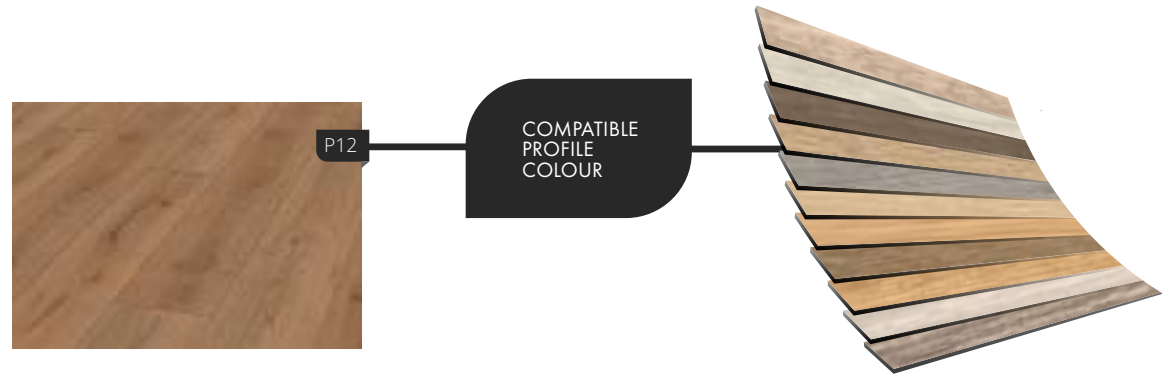

**WRG1 FLAT
SELF ADHESIVE**
900 mm & 1800 mm

All Colours

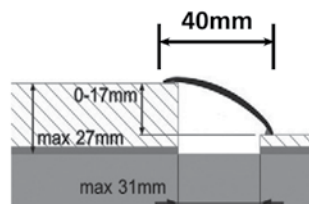

**WRG2 REDUCER
SELF ADHESIVE**
900 mm & 1800 mm

All Colours

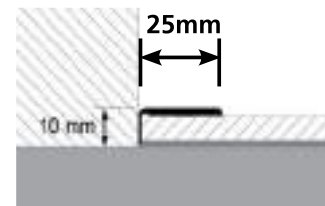
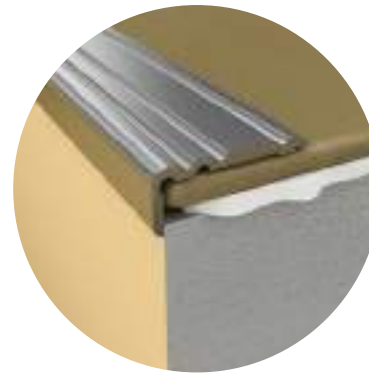

**WRG3 EDGE
SELF ADHESIVE**
1800 mm

All Colours

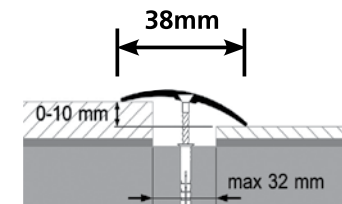

**WRG4 SCREW DOWN
REDUCER / FLAT**
900 mm & 1800 mm

Silver & Gold Only

It is important to complete your floor with quality finishing touches. Whiteriver flooring profiles come in a variety of different styles and colours to help create a seamless and streamline look for your installation. AC4 rating ensures a lasting finish.

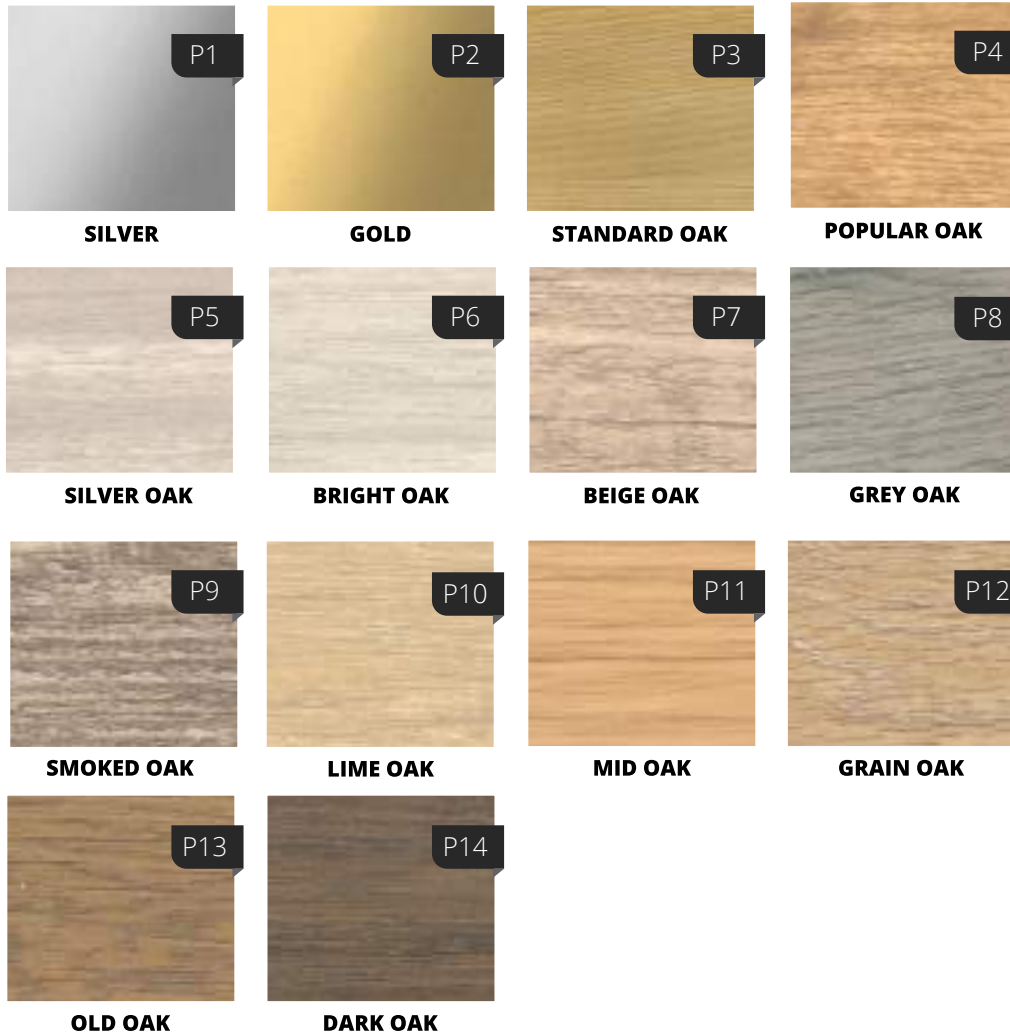

FINISHING TOUCHES

Commercial Profiles

BY WHITERIVER

Precision German manufacturing ensures a professional finish for all applications. The base section is secured to the substrate with screws while the top section can be adjusted and removed at any time. Suitable for installation in high use commercial areas.



Euro Step Stair Nosing 320
Silver 2700 mm
7 mm - 16 mm
F1625043

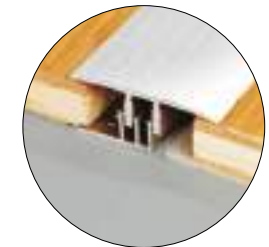

Transition 561
2 Part Screw Down
Anodized Stainless Steel
12 mm - 17 mm
F1627009



End 560
2 Part Screw Down
Anodized Stainless Steel
12 mm - 17 mm
F1627011



Reducer 559
2 Part Screw Down
Anodized Stainless Steel
12 mm - 17 mm
F1627013

Measurement Guide

● Example - Room measuring 3m x 4.5m = 13.5m²

	Feet & Inches	3' 3"	4' 11"	6' 6"	8' 2"	9' 10"	11' 5"	13' 1"	14' 9"	16' 5"	18' 0"
Feet & Inches	Metres	1.0m	1.5m	2.0m	2.5m	3.0m	3.5m	4.0m	4.5m	5.0m	5.5m
3' 3"	1.0m	1.0m ²	1.5m ²	2.0m ²	2.5m ²	3.0m ²	3.5m ²	4.0m ²	4.5m ²	5.0m ²	5.5m ²
4' 11"	1.5m	1.5m ²	2.3m ²	3.0m ²	3.8m ²	4.5m ²	5.3m ²	6.0m ²	6.8m ²	7.5m ²	8.3m ²
6' 6"	2.0m	2.0m ²	3.0m ²	4.0m ²	5.0m ²	6.0m ²	7.0m ²	8.0m ²	9.0m ²	10.0m ²	11.0m ²
8' 2"	2.5m	2.5m ²	3.8m ²	5.0m ²	6.3m ²	7.5m ²	8.8m ²	10.0m ²	11.3m ²	12.5m ²	13.8m ²
9' 10"	3.0m	3.0m ²	4.5m ²	6.0m ²	7.5m ²	9.0m ²	10.5m ²	12.0m ²	13.5m ²	15.0m ²	16.5m ²
11' 5"	3.5m	3.5m ²	5.3m ²	7.0m ²	8.8m ²	10.5m ²	12.3m ²	14.0m ²	15.8m ²	17.5m ²	19.3m ²
13' 1"	4.0m	4.0m ²	6.0m ²	8.0m ²	10.0m ²	12.0m ²	14.0m ²	16.0m ²	18.0m ²	20.0m ²	22.0m ²
14' 9"	4.5m	4.5m ²	6.8m ²	9.0m ²	11.3m ²	13.5m ²	15.8m ²	18.0m ²	20.3m ²	22.5m ²	24.8m ²
16' 5"	5.0m	5.0m ²	7.5m ²	10.0m ²	12.5m ²	15.0m ²	17.5m ²	20.0m ²	22.5m ²	25.0m ²	27.5m ²



INSTALLATION **MADE EASY**



Scan here for handy YouTube
video installation tips



Installation Tips



Care and Repair

General Guidelines

- Leave boxes unopened in room for 48 hours prior to installation.
- Inspect all boards in daylight for any visible faults or defects before installation.
- Check the sub-floor is level and even before installation.
- It is very important to sweep the floor clean. Make sure there is no grit under the underlay.
- Install 0.2 mm/500 gauge polythene on all concrete surfaces to provide a vapour barrier. All polythene joints should be overlapped and taped.
- Consult instructions and website for full details on site conditions and moisture content of subfloor.
The moisture content of cement screeds should be 2.0% CM (3% on red scale Tramex Concrete Encounter). For anhydrite/pump screeds with underfloor heating, the moisture content should be 0.3% CM (1.6% on red scale Tramex Concrete Encounter).
- Use a good quality flooring underlay for your floor.
- Select board direction e.g. towards light or longest room dimension.
- This floor requires no glue and has a simple click system.
- Never install kitchen units / islands on top of floor as this will restrict natural movement and may cause the floor to lift.*
- Install as a floating floor with room for expansion around perimeter.
- Follow installation instructions for first and second row.
- Where the same floor is being installed through adjoining rooms it is important to leave a 10 mm expansion gap under each door and install suitable profile.
- Stagger joints by 300 - 400 mm thereafter.
- Select finishing profiles, skirting, pipe covers, doorway slips.
- Use felt pads and protective castors underneath furniture legs.
- Please use suitable cleaning products for aftercare.
- Installation instructions may vary. See pack for details.

*** All floors should be broken at the doorway with expansion joint.**

Note: Sub-floors must be perfectly level to within 1 mm over 1mt before installing laminate herringbone and 3 mm over 1mt for all other laminates. Any variation in floor levels must be corrected prior to installation.

Disano Aqua Classic must be glued down to the base floor achieve water resistant rating.

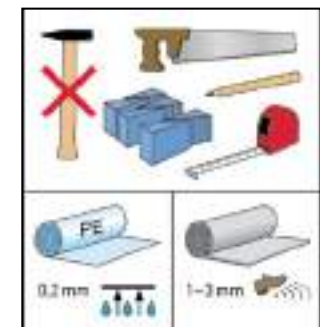
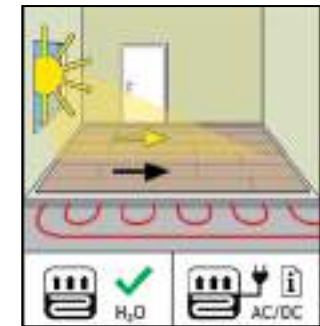

Installing your floor

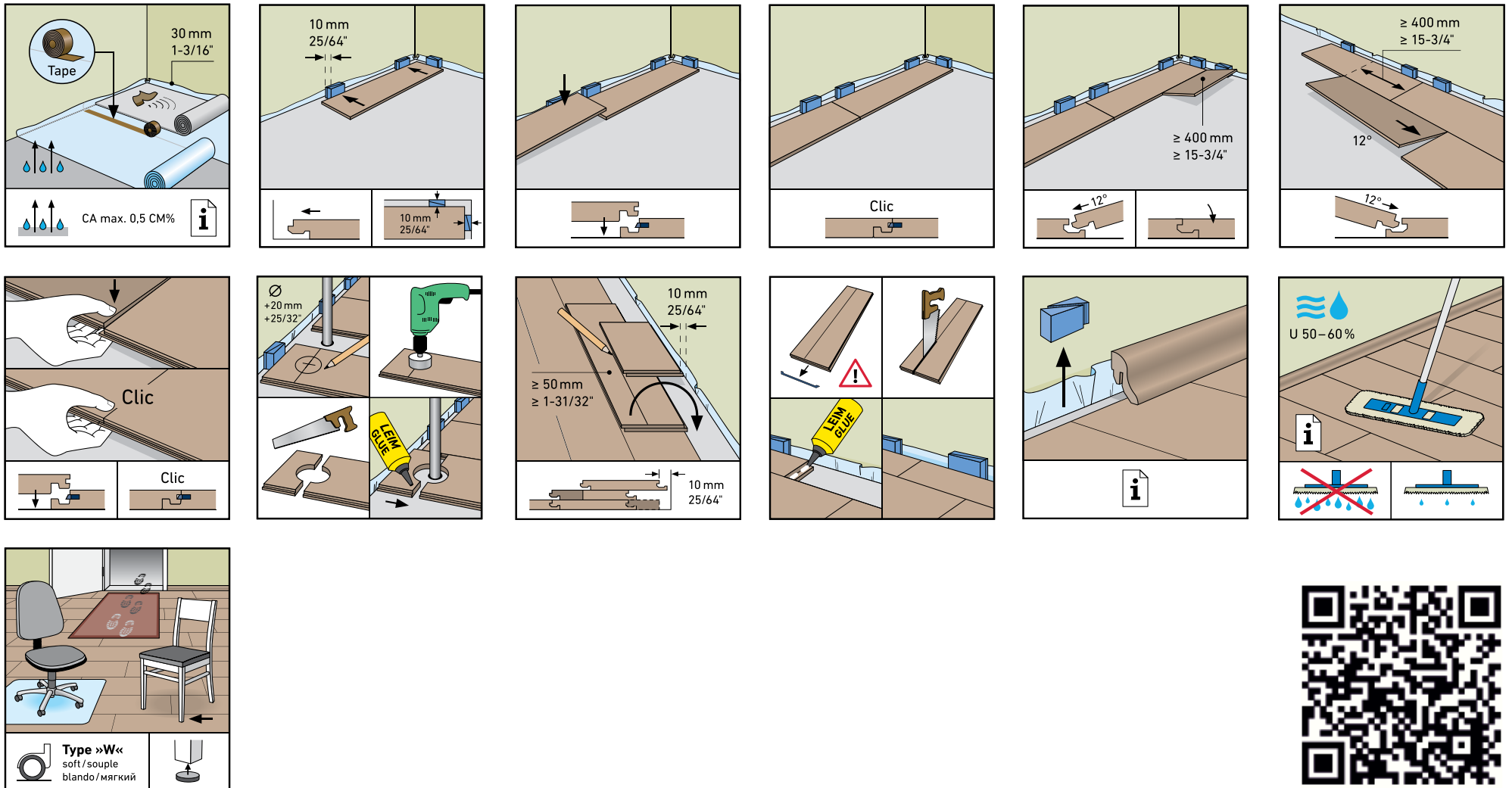

Step by step Herringbone instructions.

LAMINATE FLOORING AND UNDERFLOOR HEATING? OF COURSE!

Laminate floors are wonderfully compatible with underfloor heating.

As long as you keep just a few things in mind, nothing will prevent you from enjoying cosy warmth in your home.

Water or electric underfloor heating?

Water-based underfloor heating systems are excellently suited for laminate flooring. And these days, most electric systems can also be combined with laminate without problem. It is prudent to play it safe and ask the manufacturer whether their product is in fact compatible with laminate. State-of-the-art electric underfloor heating systems can be used without any concerns. Many older models, however, can only be turned on or off without permitting any intermediate settings. If you are planning to install laminate, the ability to adjust the temperature in steps is important. But talk to the manufacturer! Only they can guarantee the suitability of their system.

Checklist for laminate flooring and underfloor heating

- Follow the instructions of the heating system manufacturer!
- Mineral substrates must be warmed up gradually before installing the flooring, otherwise they might crack or moisture may be permanently trapped inside them.
- Ask a heating installer to test your underfloor and prepare a report on its heating response. This is essential for assessing the screed's suitability for being covered and especially important for floor surfaces that are made of or derived from wood.
- Make sure to heat up the underfloor and allow it to cool off again according to the prescribed schedule before installing the laminate. Its surface should be at least 15°C when this is done.
- To prevent moisture from rising, lay a polyethylene membrane (0.2mm thick) on a mineral substrate beneath the laminate flooring and any acoustic underlays to serve as a vapour barrier.
- It is best to use acoustic underlays from our range.
- The first time the heating system is used after installing the laminate flooring, as well as at the start of each new heating period, gradually increase the temperature in steps of 5°C per day to the maximum infeed temperature (i.e. the highest temperature of the water or other heat transferring material).
- Do not cover heated areas, as otherwise there is a risk of trapping heat and causing the temperature to rise excessively.
- Make sure that the underfloor heating can be adjusted in steps (i.e. not simply on/off). The surface temperature of the laminate flooring should not exceed 26°C.
- If you have electric underfloor heating, ask the manufacturer to confirm its suitability for laminate flooring.

Heat transfer rates depend on thickness

A material's heat transfer coefficient, or u-value, is a measure of how fast heat is transmitted through it. This varies depending on the material's thickness and thermal conductivity. A lower u-value means that more heat is transferred, while a higher one indicates greater resistance to heat flux. The assembly of vapour barrier, acoustic underlay and laminate must not have a value greater than 0.15 (m²*K)/W. A laminate floor's suitability for use with underfloor heating is inversely proportional to its u-value.

HOW TO KEEP YOUR LAMINATE FLOORING LOOKING LIKE NEW

Besides being exceptionally hygienic, laminate floors are quite easy to keep clean and in good condition.

Prevent soiling and wear

Whilst laminate flooring can be cleaned with minimal effort, it is even better to prevent it from being soiled and worn in the first place. Attach small felt glides to the legs of chairs, tables and other pieces of furniture that are frequently moved to avoid scratches and scuff marks. If you have swivelling chairs mounted on casters, make sure that the casters are of soft rubber (the kind sold for hard wood floors). Heavily used areas, like in front of desks, can also be protected with chair mats, which come in a variety of types and colours including transparent. It is also advisable to put a foot mat at your front / back door and lay dirt trapper barrier mats or runners in hallways. If, despite all your precautions, your laminate suffers minor damage such as scratches visit: www.kronotex.com/Laminate-Flooring-Guide/repairing-laminate-flooring

Sweeping, vacuuming and wiping laminate floors

It is easy to remove coarse debris or dirt such as sawdust from installing the floor using a soft broom or a vacuum cleaner fitted with a suitable tool for hard floors. However, as sweeping tends to stir up dust, we recommend vacuuming. To clean off residues and dirt that adhere to the floor, as well as marks left by rubber-soled shoes and furniture, wipe with a damp cloth. It's important that the cloth isn't too wet; it should only be slightly moist so that the floor will quickly dry again afterwards. Too much water is not good for laminate. If anything ever spills on the floor, clean it up right away! Try to wipe lengthwise along the panels. There is no need for any additional treatment.

STEAM CLEANING MACHINES ARE NOT SUITABLE FOR LAMINATE FLOORS.

Suitable cleaning products for laminate flooring

We recommend Clean & Green Intensive Active Cleaner where damp cleaning is required. Add 1/2 a dosage cap to 5 litres of clean water. A damp microfibre mop should then be used to apply the solution. This point is critical to the correct maintenance of your laminate floor. DO NOT clean your floor with excessive amounts of water and always avoid letting water sit on the surface. NEVER use steam mops on laminate floors.

To increase durability and help protect against moisture penetrating from above we recommend Clean & Green Aqua Shield.



ACTIVE CLEANER
500ML / F2012018



AQUA SHIELD
1LT / F2012022

Ideal ambient conditions for laminate flooring

The best ambient conditions for laminate are a temperature of 20°C to 22°C and relative humidity of 50-60%. A bit more or less than this isn't a problem – these values naturally fluctuate in any case. But if the relative humidity persists at a significantly higher or lower level, we recommend purchasing a dehumidifier or humidifier as the case may be. Besides being good for the laminate, it also creates a healthier, more pleasant indoor climate.

Summary of how to care for laminate flooring:

- Remove loose dirt and debris with a soft broom or vacuum cleaner.
- Use a damp cloth to clean off sticking residues.
- Wipe parallel to the panels' long sides.
- Use a special-purpose laminate cleaner to get rid of stubborn dirt.
- Place felt glides under furniture legs.
- Use soft rubber chair casters.
- Lay dirt trapper mats or runners at entrance doors and in hallways.
- In commercial establishments, use barrier mats, runners etc. to create walk-off zones.

architects & *designers*

We have a long tradition of working with Architects & Designers on both commercial and residential developments. Along with offering our product range which is displayed on our site, we also offer a bespoke product design service for larger projects, we have expertise dealing in both new design and protected restoration. Our company has worked on many leading projects and have expertise in the following areas.

- Hotels
- Pubs & Restaurants
- Retail
- Residential
- Health care
- College/Universities
- Student accommodation
- Museums

Recent projects of note include Lansdowne Place, Adare Manor Hotel and Golf Resort, Becton Dickinson Research Centre, Mount Juliet Estate, Hanover Quay, Tayto Park, Cliff House Hotel, Kerry Group H.Q., Carechoice Nursing Home, UCC Student Campus.

Our company is both FSC & PEFC certified and we also follow and comply with EU policy on the importation and sale of wood products. If you require any further information for product specification, or simply want to discuss our product offering we are more than happy to help you. We also have a full product showroom in Dunleer, Co. Louth, which is available by appointment. Please do not hesitate to contact us to discuss any requirements you may have. Tel: 041 686100 or sales@wrg.ie



Whiteriver

wood for living



www.wrg.ie